

## SECTION 4

### OPERATING THE COACH

#### 4-1. IDENTIFICATION PLATES

There are a number of identification plates and decals (fig. 4-1) designed to assist you in licensing and registering, as well as certain caution and warning plates (do's and don'ts) for your comfort and safety. Listed below are the plates we feel you will need to license and register your coach.

#### NOTE

When reference is made throughout the manual to left and right sides, they will always be in relation to you as you face the front of the coach while inside of it.

a. Coach Serial Number Plate. Contains the coach serial number and is located on the left hand side of the windshield, mounted to the dashboard and facing outward. View the plate by looking through the windshield into the driver's compartment.

b. Engine Identification Plate. Contains engine model and serial number information and is located on the engine oil pump. To read, remove the engine service access panel (fig. 4-2) at the right rear exterior of the coach.

c. Engine Emission Certification Decal. Contains the engine exhaust emission data and timing data necessary to comply with the Federal Clean Air Act. For the 2900R use data indicated for the Chrysler 440-1 engine. The decal is located on the left (inboard) valve cover and is accessible through the engine/transmission service door. On early models, decal was on kitchen window.

d. National Highway Traffic Safety Administration Plate. Contains important data on weight distribution in conformance with Federal standards. It is located on the coach exterior to the rear of the passenger door.

e. State Identification Plate. Contains coach serial number, plan approval, and date of manufacture and is located on the coach exterior to the rear of the passenger door. This plate is furnished by the state in which your coach is registered and may not be required in all states.

f. Tire and Rim Plate. Contains important tire sizes, pressures and loadings, and is located on panel behind drivers seat.

g. Recreational Vehicle Emblem. Contains the recreational vehicle institute emblem and manufacturer's registration number. It is located above the state identification plate near the passenger door.

h. Other Plates. There are additional plates, decals, and stencils used throughout the coach that are described within each pertinent section.

#### 4-2. BREAK-IN RECOMMENDATIONS

For the first 500 miles, the coach road speed should not exceed 50 miles per hour in "D" range, or an engine speed of 3000 RPM in the lower ranges. Work up to this speed gradually during the first 200 miles and vary the speed periodically instead of driving at a steady pace for long periods.

#### *Caution*

Monitor engine temperature gage frequently to prevent engine overheating. Temperature should not exceed 250°F.

During the succeeding 2000 miles of operation, the road speed may be gradually increased to complete the "break-in" process.

Your motor coach should not be loaded in excess of the recommended gross vehicle weight (GVW) as shown in Section 6. It is important that the load be distributed in a proper proportion between the front and rear tires at the ground. Refer to tire and rim plate (fig. 4-1) for load capacity at recommended inflation pressures. Weigh the front and rear of a fully loaded coach, separately, on a standard scale. Your coach has been designed from the ground up to provide proper balance and weight distribution between the front and rear tires so you can enjoy a smooth nonpitching ride. A little care on your part when stowing gear on board will maintain this balance and make your trip more enjoyable.



Good driving practices, supplemented by regular lubrication and maintenance, will do much to keep your motor coach running at its top efficiency. Establish a regular service schedule for your coach and become acquainted with the maintenance services contained in this manual. We urge you to read the maintenance instructions thoroughly for details on servicing procedures. If you are operating under severe conditions not fully covered in this manual, consult your FMC Recreational Vehicle Dealer or the Factory Service Department to determine the best maintenance intervals for such conditions.

#### 4-3. KEYS

There are three keys to your motor coach: an ignition key, a passenger door key, and an access door key. Record the numbers stamped on each key in the event of loss.

#### 4-4. LOCK YOUR COACH

Always remove ignition key and lock all doors, windows, and access panels when leaving the coach unattended, even in your own driveway. Try to park in a well lighted area and never invite theft by leaving articles of value exposed to outside view.

#### 4-5. EXTERIOR COMPARTMENTS (FIG. 4-2)

We suggest that you become acquainted with each of the exterior storage and service access compartments. With your compartment key, walk around the coach beginning at the right front and examine the compartments as follows:

**a. Fresh Water Fill.** Located forward of the driver's seat, this double-lock compartment provides access to the filler for the fresh water tanks, the windshield washer reservoir, and the hydraulic brake master cylinder. Early models had the fresh water fill on the right side along with the windshield washer reservoir. Check your coach for configuration. To fill water tanks, remove plastic cap and fill with a hose or water container. Keep plastic cap on filler tube when not in use. Remove cap from brake master cylinder to check fluid level; fluid should be near the top. Keep master cylinder filled for safe operation.

**b. City Water Pressure Connection.** Located to the rear of left front wheel, this connection is simply "hooked in" to a city pressure system for fresh water supply. The connection is a 3/4-inch garden hose swivel type equipped with a removable plastic cap and a "press-to-operate" drain button. No key is required for access.

**c. Plumbing and Heating Service.** Located on the left side of coach, this single-lock compartment contains the hot water heater controls and furnace. Accessible are: water heater air and intake vents, pilot reset button, gas control valve, temperature relief valve, water tank drain, and the furnace air inlet and exhaust vents.

**d. Waste water and Sewage Tank Drain.** Located on the left side of coach, this drain is used for sewage discharge. The sewage hose is stored in a container under the coach just aft of the front wheels on the same side as the sewage drain valves. Waste water and sewage tank drain valves are accessible from ahead of the left rear wheels. No key is required for access.

**e. Fuel Tank Fill.** Located on the left side of coach behind the left rear wheel, this single-lock compartment contains the fuel filler and cap.

**f. 110-Volt Service Line and Auxiliary Power Unit (APU).** Located on the left side of the coach behind the left rear wheel, this single-lock compartment contains the 110-volt service line and the auxiliary power unit (APU). Pull out line to hook up to campground electrical power. The APU is for use in areas where campground power is not available.

**g. Engine, Transmission, and APU Service.** Located at rear of coach, this single-lock compartment provides access to engine oil fill, transmission oil fill cap, the transmission oil dipstick, and the auxiliary power unit (APU).

**h. Radiator Fill Service.** Located at the center rear of coach, this compartment provides access to the radiator filler cap. Coolant level should be within approximately 3-1/2 inches of top of filler neck; keep filled for safe operation. No key is required.

**i. Engine Service.** Located on the right side of coach at the rear, this single-lock compartment provides access to the engine oil dipstick, power steering reservoir, and automotive batteries. Engine dipstick should read at the "FULL" mark, power steering reservoir fluid should be close to the top, and battery should be filled with distilled water to split ring level.

**j. Ski Storage Compartment.** A ski storage compartment is accessible from either side of the coach. Each compartment door is secured by the compartment key.

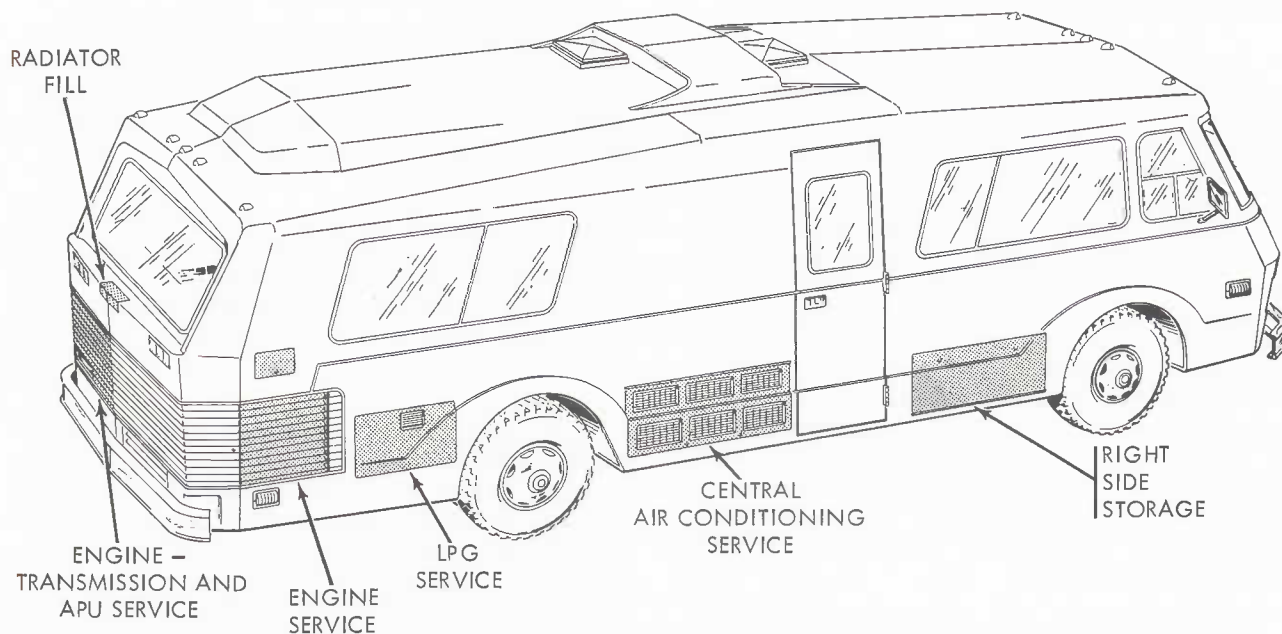
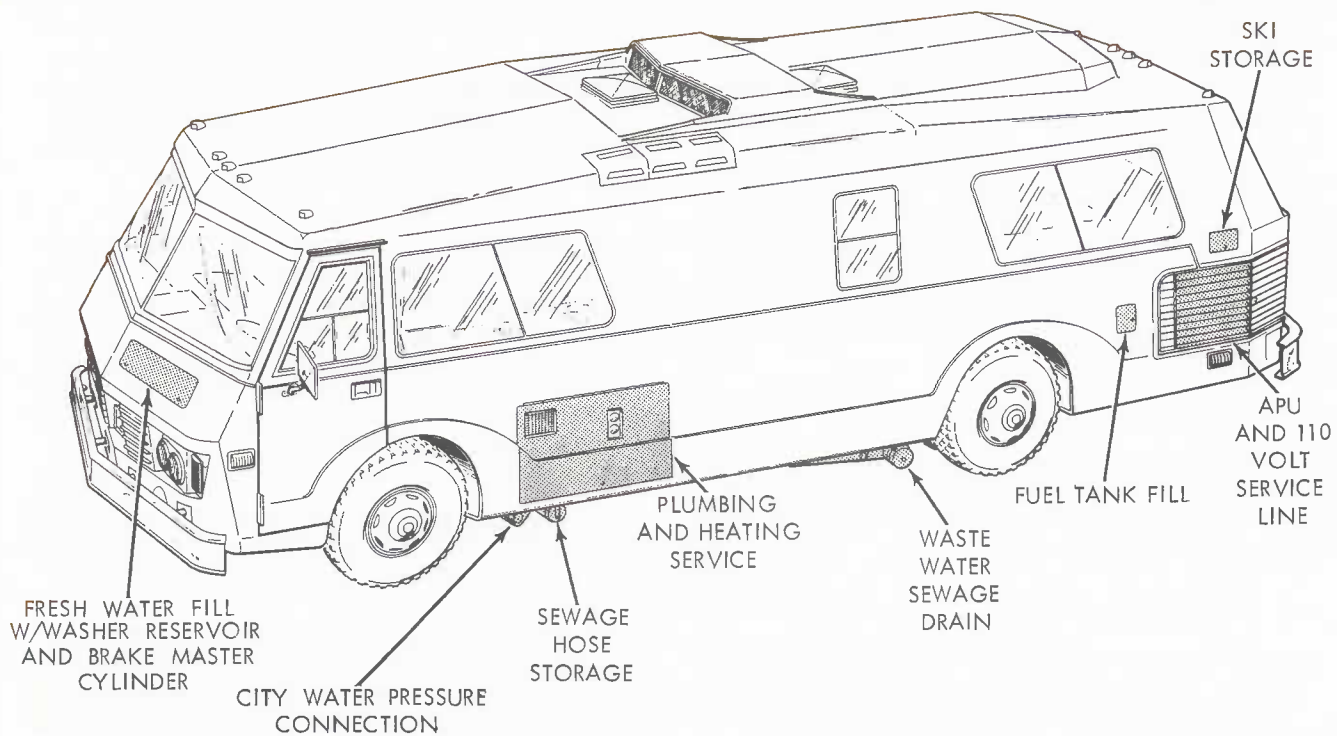

SD-372

Figure 4-2. Exterior Compartments

k. Liquid Petroleum Gas (LPG) Service. Located on the right side just behind the right rear wheel. It contains the LPG tank complete with fill valve, main shut-off and pressure relief valve, regulator, and gas level meter. The outage valve contains a vent hose to discharge any excess gas to the atmosphere. No key is required; lift latch.

**Warning**

Make certain LPG valve is closed before refueling. See Section 5.

l. Central Air Conditioner (110-volt) Service. Located on right side just behind the passenger door, this double-lock compartment provides mounting space for a front and rear air conditioning system operating from 110-volt power. All controls for the central air conditioning system are located above the clothes closet (see Section 5).

m. Right Side Storage Compartment. Located forward of the passenger door, this double-lock compartment is used for storage and is also accessible from inside.

4-6. BUMPERS (fig. 4-3)

Plated steel front and rear bumpers, fitted with compression-leaf springs (brackets) protect the coach from damage while parking or from a minor collision when moving. Earlier models were equipped with "energy absorbers"; four single energy absorbers on the front and two tandem-mounted energy absorbers on the rear.

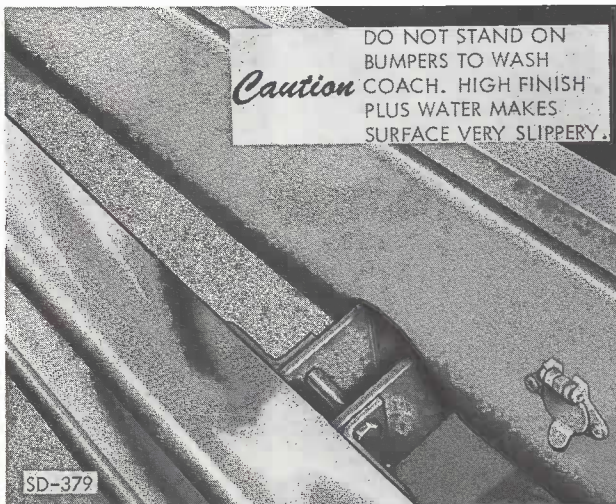

Figure 4-3. Trailer Connector and Bumper

4-7. TRAILER ELECTRICAL CONNECTOR (fig. 4-3)

The trailer connector at rear of coach connects the trailer lights into the coach automotive electrical system. When connected, the coach light switch and brake switch controls the trailer lights. To use: Lift connector cover and insert trailer plug. Lock plug in place by hooking end of cover over the plug. To remove, lift cover and pull trailer plug from connector.

**NOTE**

This completes the exterior walkaround; the following paragraphs deal with the coach from the inside.

4-8. DRIVER'S AND PASSENGER SEATS

a. Driver's Seat (fig. 4-4). The driver's seat adjusts fore and aft through six positions for your leg and arm comfort. This seat also pivots to the right, which makes getting in or out of it very easy. Place yourself in the seat and adjust the forward position to your comfort by moving the fore and aft slide latch (under the seat) to the left. Move seat forward or backward until you feel comfortable with your right foot on the accelerator pedal. Release slide latch. Latch will "click" when seat is secure in track. Raise arm rests; adjust and fasten seat belt or shoulder belt. To swing out of the seat, simply lower arm rest, release seat or shoulder belt, and push down on seat pivot lever located beneath seat frame on driver's seat pedestal. If the seat is in the full rearward position, you will have to move it forward (about 2-1/2 inches) to allow space for the seatback to clear the galley partition.

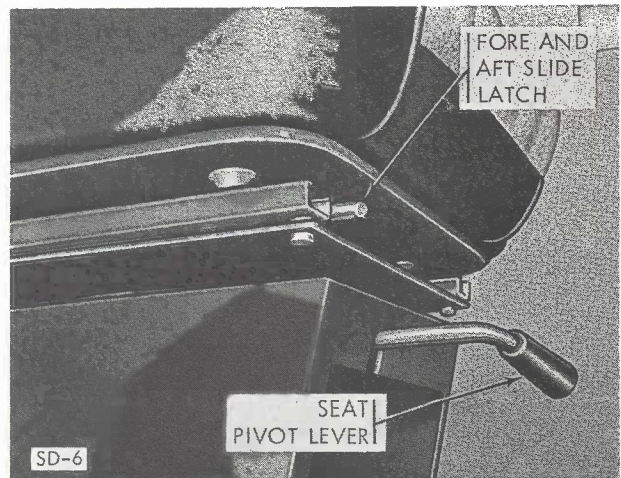

Figure 4-4. Driver's Seat-Adj

b. Passenger Seat (fig. 4-5). The passenger seat on floor plan "A" only adjusts fore and aft (four positions) in same manner as the driver's seat. To move fore and aft slide latch to your left (with left hand) to move seat forward or backward. Release slide latch and seat will click into position. On coaches equipped with a dinette (floor plan "A") the passenger seat arm rests can be folded down if desired. When dinette area (floor plan "A") is used for sleeping, passenger seat must be moved to its full forward position. Passenger seat is equipped with two seat belts and headrests.

On coaches equipped with a sofa-seat arrangement (floor plan "J") passenger seat backrest moves forward against dash to become a bed headrest. This seat is equipped with two seat belts and is a high back design to provide headrest when in the passenger position.

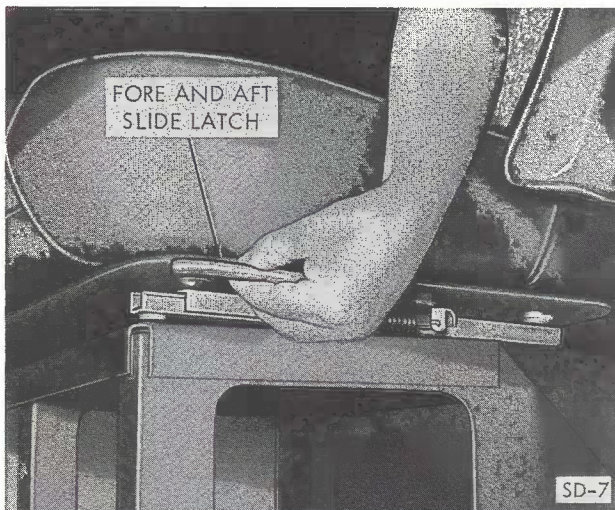

Figure 4-5. Passenger Seat-Adj Lever

c. Passenger Door Step (fig. 4-6). The passenger door is equipped with an "EAS-LIFT" pull-out step for ease of entry and exit. Pull out step from under door sill and push on step to lock in extended position. Lift step to unlock and slide under door sill before moving coach.

#### 4-9. DRIVER'S INSTRUMENTS AND CONTROLS (fig. 4-7)

Familiarize yourself with the driver's instruments and controls BEFORE YOU OPERATE your motor coach. The instruments provide useful information; check them frequently as you drive.

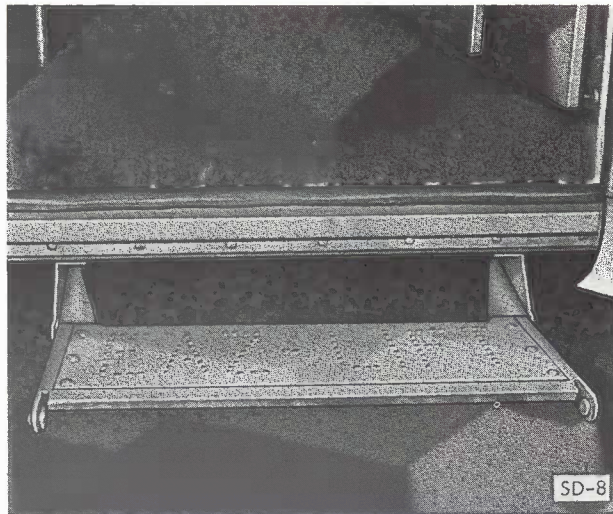

Figure 4-6. Passenger Door Step

a. Starting-Ignition Switch. The key-operated starting-ignition switch has four positions: "ACCY," "OFF," "IGN," and "START." When the key is turned to the "ACCY" position, the following items are activated: windshield wipers and washers, heater and defroster, and automotive air conditioning system. Turning to the "IGN" position, activates the engine ignition system, instrument panel lights, brake lights, and turn signal lights. To start engine, turn key to extreme right; when engine starts, release pressure on key and it will return to the "IGN" position. To remove key, turn to center "OFF" position.

b. Speedometer. Located directly in front of driver, the speedometer is graduated in increments from 0 to 100 mph. It is equipped with a mileage odometer to record total miles traveled.

c. Tachometer. Located directly in front of the driver, the tachometer records engine revolutions per minute. Tachometer is graduated in increments reading from 0 to 5000 rpm.

d. Engine Oil Pressure Gauge. Located above and to left of speedometer, this gauge is graduated in increments reading from 0 to 150 pounds per square inch. Gauge indicates engine oil pressure but not oil level. Pointer should indicate 65 pounds minimum when engine is operating at cruising speed and normal temperature.

e. Fuel Gauge. Located below engine oil pressure gauge. With the ignition switch in IGN position, the pointer will indicate amount of fuel in tank.

f. Water Temperature Gauge. Located above tachometer, this gauge indicates engine coolant temperature. Pointer will normally stay near cen-

ter, but may rise slightly in traffic or under heavy load.

## Caution

Monitor temperature gauge frequently to prevent engine overheating. Temperature should not exceed 250°F.

g. Alternator Indicator (Voltage Gauge). Located below tachometer, the alternator indicator indicates whether battery is being charged or discharged. It is graduated in increments reading from 0 to 16. Pointer will normally stay centered while driving.

h. Turn Signal Indicators. The turn indicators (green light) flash in unison with the outside lights when the turn signal is operated.

i. High Beam Indicator. Beam indicator (blue light) "BRT" comes on when the headlights are on high beam. It is readily visible at night.

j. Brake Indicator. Brake indicator (red light) "BRK" comes on if coach parking brake is in the "UP" (on) position, or if the dual booster brake system should fail.

k. Engine Stopped Indicator. Indicator (red light) "ENG" comes on if engine stops. If light comes on, restart engine.

l. Wiper/Washer Control Switches. Located on panel to left of driver, these two switches control the left and right windshield wipers. All wipers have two speeds for clarity and safety. Rotate switch

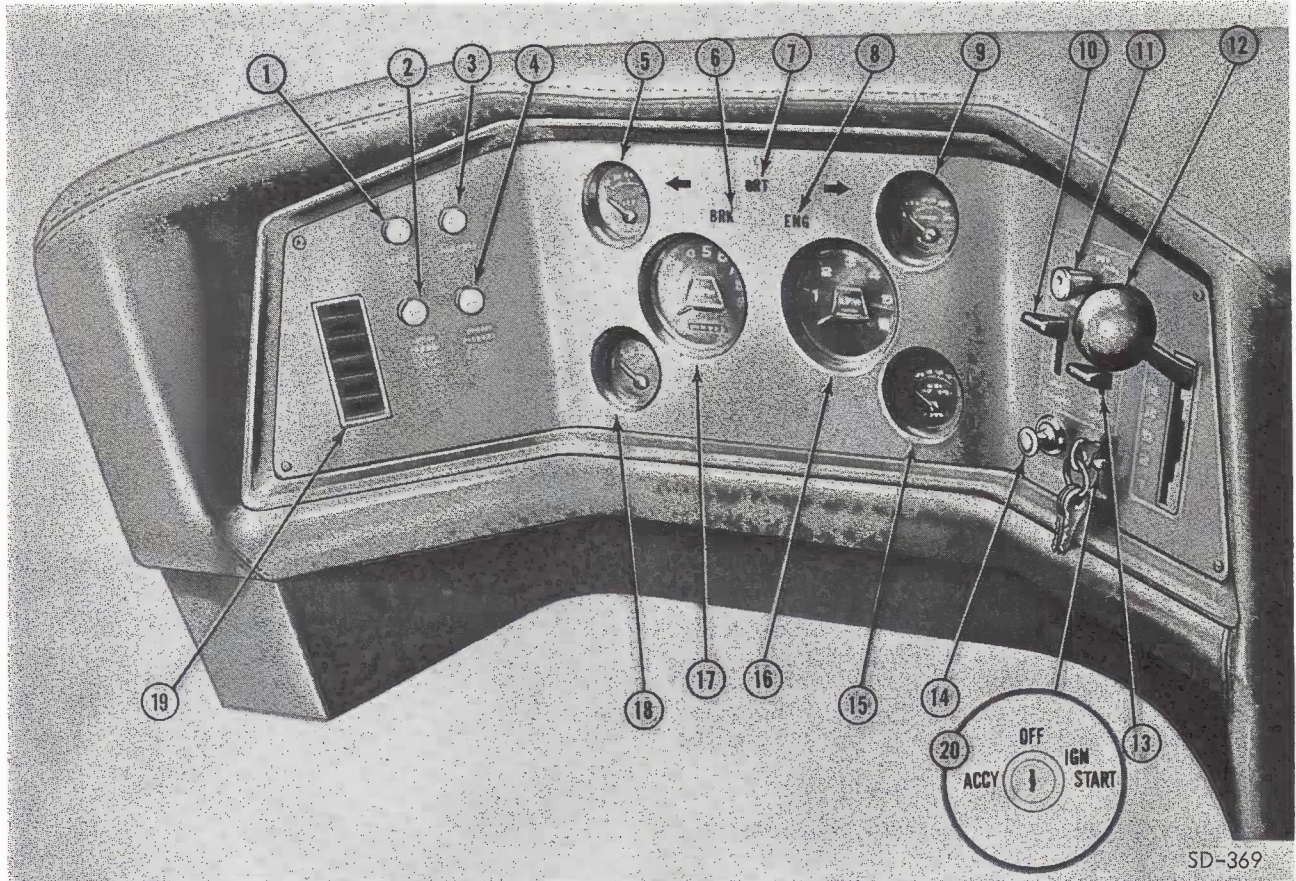

- |                  |                                 |                                |
|------------------|---------------------------------|--------------------------------|
| 1. LIGHT SWITCH  | 8. ENGINE                       | 14. CIGAR LIGHTER              |
| 2. LEFT WIPER    | 9. WATER TEMPERATURE            | 15. ALTERNATOR INDICATOR       |
| 3. HAZARD SWITCH | 10. HEATER                      | 16. TACHOMETER                 |
| 4. RIGHT WIPER   | 11. BLOWER                      | 17. SPEEDOMETER                |
| 5. OIL PRESSURE  | 12. TRANSMISSION RANGE SELECTOR | 18. FUEL                       |
| 6. BRAKE         | 13. A/C-HEAT SELECT             | 19. A/C VENT                   |
| 7. HIGH BEAM     |                                 | 20. STARTING - IGNITION SWITCH |

Figure 4-7. Instrument Panel

to left for "OFF," one position to right for "HALF" speed, and two positions to right for "FULL" speed. Push knob in to activate washers as desired; release knob to stop washers. Pushing knob activates an electric pump to spray fluid (water, windshield solvent) from washer reservoir as desired. Wet glass with washers before operating wipers. If interior of coach is cold, operate the defroster for a few minutes, after the engine has warmed up, to reduce possibility of smearing or freezing the fluid on the windshield. During cold weather make sure washer solution contains antifreeze specifically made for this use.

**m. Hazard Switch.** Located on panel to left of driver, this switch activates the emergency warning system and is not intended for use when coach is in motion. Pull out to place hazard switch in "ON" position. The front turn signal lights (park) and rear brake lights will flash. If it is necessary to leave the coach to go for service, the flasher system will continue to operate even with the ignition key removed.

**n. Lights Switch.** Located on the left panel is the main light switch for your motor coach. The switch controls all the exterior lights and the instrument panel lights. Pulling knob to first stop activates all the exterior lights, except the headlights; pulling knob all the way out turns on headlights. Brightness of instrument panel is controlled by rotating knob to left for bright, to right for dim. The hi-beam foot switch is on the left side of the floor board.

**o. Air Conditioning and Heater Controls.** Located on right panel above the ignition switch are the controls for the automotive air conditioning and automotive blower. The blower knob controls the speed of the blower, the "HEATER" lever controls the heat output ducts between full open "HIGH" or fully closed "OFF," the "SELECT" lever controls the air output for either "AC" air conditioning, "HEAT" for warm air heating and the defroster.

**p. Transmission Range Selector.** Located to the right of driver, the selector has six positions; "P" or park, "R" or reverse, "N" or neutral, "D" or drive gear, "2" or second gear, "1" or low gear. The "P" parking position supplements the parking brake by locking the transmission. Engine can be started in this range. The "1" (low gear) is used for climbing very steep hills and for "engine braking" at low speeds when going downhill.

## Caution

Never use "P" while the coach is in motion. Always set parking brake while in this range. When parking on an incline put range selector in "N", apply parking brake, then move selector to "P" position.

The "R" (reverse) position is used to back your coach and only after the coach has been stopped completely. An audible warning buzzer is activated when selector is placed in "R" position to warn pedestrians that coach is going to back up. The "N" (neutral) is used for standing for prolonged periods with the engine running. Engine can be started in this range. The "D" (drive gear) is used for most city and highway driving. The "2" (second gear) is used for driving slowly in traffic or on mountain roads where more precise speed control is desirable. It is used also when climbing long grades, and for "engine braking" when descending moderately steep grades.

## Caution

Do not exceed 25 miles per hour in "1" range, or 55 miles per hour in "2" range.

**q. Parking Brake (fig. 4-8).** The parking brake lever is located to the left of the driver's seat. Pull up to vertical position to set brakes; push down to release. Parking brake lever cable tension is adjustable by turning knob on lever. Turn knob counterclockwise (left) to relieve tension; clockwise (right) to increase tension.

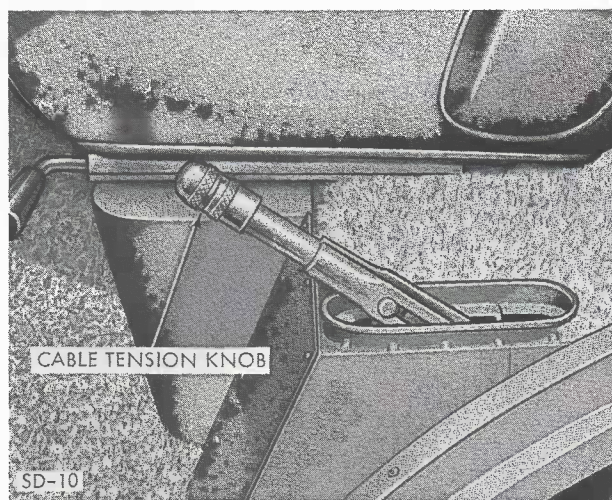
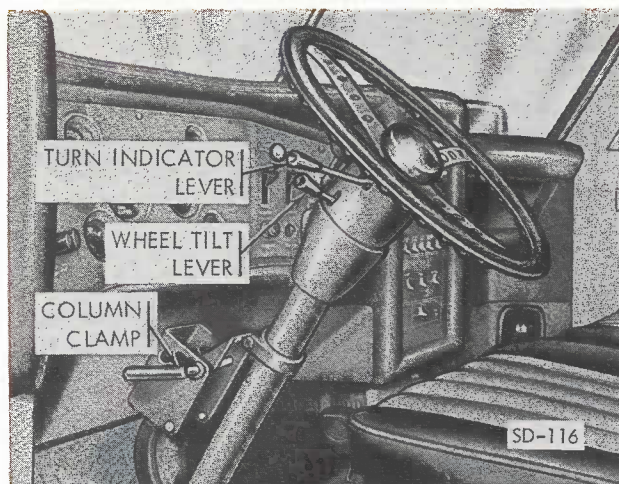
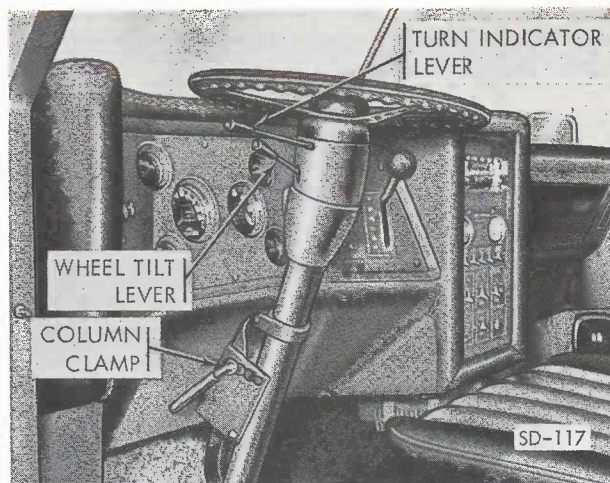

Figure 4-8. Parking Brake Lever



Full Tilt-Full Rearward



Flat Wheel-Full Up

Figure 4-9. Steering Wheel

*Caution*

Warn children to stay away from operator's controls, especially parking brake and transmission range selector.

r. Steering Wheel. The steering column and the steering wheel are both adjustable to afford you maximum comfort and position selection (fig. 4-9). To adjust column, hold steering wheel with right hand and loosen column clamp with left hand. Select the column position most comfortable for you from full up to full down, then tighten column clamp. Adjust wheel by pulling tilt lever up and pulling on upper rim of wheel to set wheel at an angle most comfortable for you. Wheel will lock in place when tilt lever is released. The horn button is at center of steering wheel and activates a dual set of horns located under front cowling.

s. Turn Signal Lever. The turn signal control lever is on the left side of the steering column below steering wheel. Pull lever to signal for a left turn; push lever to signal for a right turn. Use turn signals for left and right turns, when changing lanes, or when pulling away from a curb. Signal your intention as far ahead of the actual maneuver as possible. The signal will remain on until the normal turn is completed or until the lever is returned to neutral by hand.

t. Sun Visors. Your coach is equipped with left and right visors for sun control in conjunction with the tinted windshield. Visors swing down for use; swing up against roof when not in use. Visors are safety padded.

u. Mirrors. Left and right side view mirrors and an interior rear view mirror are installed to afford the driver all possible vision to the rear. Mirrors should be adjusted to give driver a clear view of left and right sides of coach. Mirrors swivel in and out and can be tilted up or down to suit driver's needs.

v. Map Lights (fig. 4-10). Overhead map lights, one above driver's seat on left ceiling and one above passenger seat on right ceiling, illuminate area for reading. Each light has its own switch to suit individual requirements.

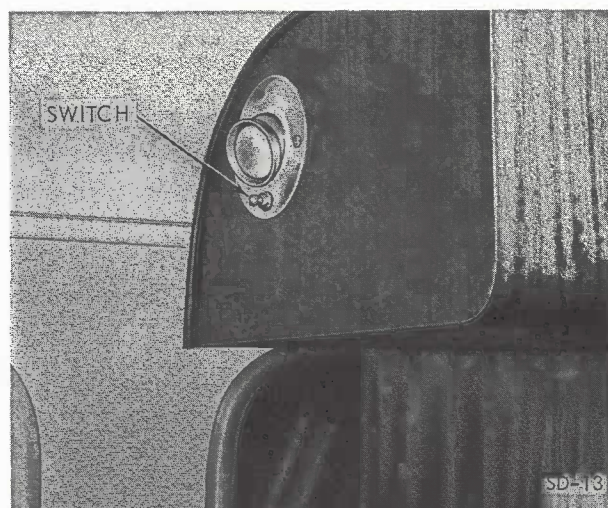

Figure 4-10. Map Light

w. Driver's and Passenger Windows (fig. 4-11). Sliding window panels for ventilation and signaling are contained in the driver's door and passenger window. Pull or push window handle to open or close

windows. If coach air conditioning is operating, keep these windows, and others throughout the coach, closed for efficient cooling.

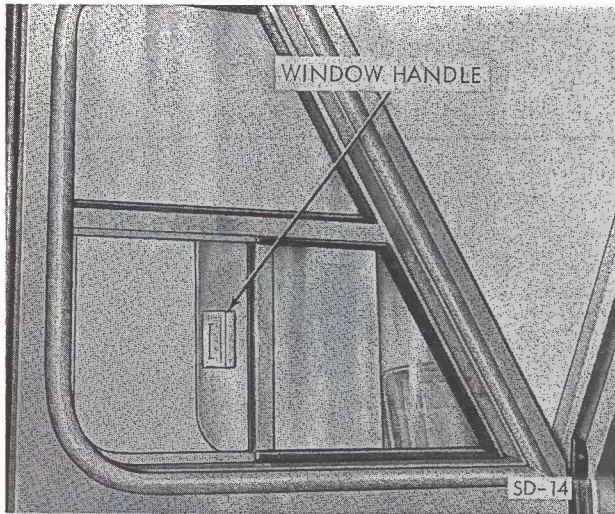

Figure 4-11. Driver's Sliding Window

**x. Seat Belts.** Seat belts are provided on the driver's and passenger seats up front and on the rearmost seat in the dinette on floor plan "A" coaches. The driver's seat also has a shoulder belt that can be used in lieu of the seat belt, if desired. All belts are fastened to the coach hull and keep driver and passengers moving with the coach. When the coach is in motion, it is ESSENTIAL that all occupants have their seat belts fastened – even a short but hard brake application can cause injury to an unbuckled occupant.

## Warning

Driver should insist that all passengers fasten seat belts before moving coach. Take no chances; buckle up.

**y. Brake Pedal.** The hydraulic brakes on your coach are activated by the brake pedal. Dual vacuum booster cylinders assist you in applying the brakes. Should the booster action fail, the hydraulic brake system will function without it to apply the brakes. Any difficulty with the brake vacuum boosters should be checked by a qualified service technician.

**z. Accelerator Pedal.** The accelerator pedal opens and closes the engine carburetor throttle valve and thereby controls the coach speed. This pedal also controls the transmission low-gear kickdown mechanism to obtain rapid acceleration of coach at slow speeds.

### 4-10. BEFORE STARTING CHECKLIST (table 4-1)

Before starting on a trip, it is wise to make a check(✓) of the coach running gear and its interior equipment. Such a check can prevent unnecessary delays and thereby make your trip more enjoyable. Replace any worn or damaged parts; bring oil, water, and coolant up to proper level.

Table 4-1. Before Starting Checklist

From outside ✓ that:	By checking through:
Fresh water fill cap is in place and windshield washer reservoir is filled.	Left front fresh water fill access. (Early models fill was on right side.)
Brake master cylinder is filled.	Left front brake cylinder and windshield washer access.
Hot water tank drain is closed and furnace air exhaust and intake vents are clear and free of dust.	Plumbing and heating service access on left side.
Fuel tank filler cap is in place and tight.	Fuel tank access on left side.

Table 4-1. Before Starting Checklist (Continued)

From outside ✓ that:	By checking through:
110-volt service line is stowed.	APU service access at rear.
Auxiliary power unit (APU) and transmission oil levels are at or near "FULL" mark.	Engine-transmission service access at rear.
Engine oil level is at or near "FULL" mark, power steering reservoir fluid is near top, and automotive battery is filled with distilled water to split ring level.	Engine service access at right rear side.
Radiator coolant level is no lower than 3-1/2 inches below top of filler neck.	Radiator fill service access at center rear.
LPG fill cap is in place and secure, and shut-off valve is closed.	LPG service access on right side.
Sewage hose is in container, drain covers and straps are in place, and waste water and sewage valves are closed.	Waste water and sewage tank access on left side.
Domestic batteries are filled with water (distilled water recommended)	Access cover under driver's toe board
City water pressure connection cap is in place and secure.	City water pressure connection access on left side.
Tires are free of foreign objects and are inflated to correct pressure.	Inflate to 75 psi.

Table 4-1. Before Starting Checklist

From outside ✓ that:	By checking through:
Passenger door step is up and under door sill.	See figure 4-6.
From inside ✓ that:	Action (See fig. 4-7):
There is an adequate amount of fuel in tank.	Turn ignition key to "IGN" position and read fuel gauge.
Brake red indicator light (BRK) is on.	Turn ignition switch to "IGN" position and set parking brake; red light should be on.
Red engine stopped indicator light (ENG) is on.	Turn ignition switch to "IGN" position; red light should be on.
Reverse warning buzzer is working.	Turn ignition switch to "IGN" position; place transmission selector lever in "R"; buzzer should be on.
Front windshield wipers and washer operate.	Turn on each windshield wiper and activate washer; check wipers through both speeds.
Brake pedal operates freely, and feels solid when depressed.	Depress brake pedal. It should feel solid and begin to grip after about 3/8 inch of movement. Rear brake lights should go on.

**NOTE**

Ask your passenger or co-pilot for an assist when checking exterior lights.

All exterior lights are working.

Pull light switch to first position. All lights should go on, except headlights; pull switch all the way and headlights should go on. Depress foot switch and check for high-low beam operation. In high beam position, blue light (BRT) of high beam indicator should be on. Low beam, outboard lights; high beam, inboard lights.

Table 4-1. Before Starting Checklist (Continued)

From inside that:	Action (See fig. 4-7):
Turn signal lights flash when turn indicator is set in left or right turn position.	Set indicator in left position, left front turn signal (park) and left rear brake lights should flash; set indicator in right position, right front turn signal (park) and right rear brake lights should flash. Turn indicators on panel should flash for left or right turn.
Hazard warning lights flash in unison when switch is on.	Turn on hazard switch, front turn signal (park) lights and rear brake lights should flash in unison.

## 4-11. STARTING THE ENGINE

### Warning

Exhaust gases contain carbon monoxide; a potentially toxic gas that by itself is colorless and odorless. To avoid inhaling these gases, the following precautions should be observed:

Do not run the engine (including the APU) in a closed garage or in confined areas any longer than needed to move the coach in or out of the area. The best protection against carbon monoxide entry is a properly maintained engine exhaust system. Whenever a change is noticed in the sound of the exhaust system, when exhaust fumes can be detected inside the motor coach, or when the underside of the motor coach is damaged - have a competent mechanic, preferably an FMC authorized service center mechanic, inspect the complete exhaust system and adjacent body areas for broken, damaged, or mispositioned parts, deterioration, open seams or loose connections which could permit exhaust fumes to seep into the coach. In addition, inspect the exhaust system during lubrication or oil change periods. Replace or adjust as required.

a. Normal Starting-Engine Cold. Set parking brake in "UP" (on) position, place transmission range selector in "N" (neutral) or "P" (park). Depress accelerator pedal to the floor and release. Turn ignition key to the "START" position and release when engine starts. Allow engine to idle for a short period (approximately 2 minutes) to allow engine to come up to normal operating temperature (185°F).

### Caution

The starter should not be operated for longer than 1 MINUTE intervals. A waiting period of at least 2 minutes between such intervals should be observed to protect starter from overheating.

b. Normal Starting-Engine Warm. Same as above except hold the accelerator pedal part way down while starting.

c. Extremely Cold Weather Starting (Below Zero). Set parking brake in "UP" (on) position and place transmission range selector in "N" (neutral) or "P" (park). Depress accelerator pedal to floor and release. Then hold pedal part way down while starting.

d. Flooded Engine Starting. Depress the accelerator pedal fully and hold to the floor until engine starts. This will clear excess fuel from carburetor.

e. Assist Starting. Assist starting CANNOT be accomplished by pushing or towing. Use a booster battery or jumper cables from another vehicle in conjunction with coach automotive battery.

### Caution

Make certain negative cable from booster battery is connected to negative terminal on motor coach battery. Each post is stamped on top (-) negative; (+) positive.

## 4-12. SHIFTING THE TRANSMISSION

The transmission range selector is mounted on the right side of the instrument panel. When ready to roll, release parking brake and move selector from "P" or "N" to the desired drive position. Selector can be moved from "P" to "R" only by moving lever past gate to the left. Use "R" range only when vehicle is stopped; "N" when motor coach is standing for long periods with engine running.

Most driving will be in the "D" range when in cities and on relatively level highways. If it's slow going in traffic, shift to the "2" range for more precise speed control.

When driving in the mountains the "2" or "1" range position should be selected on upgrades which require a heavy throttle for 1/2 mile or more. This will reduce the possibility of overheating the transmission. Also use "2" range for "engine braking" when descending moderately steep grades.

### *Caution*

Do not exceed 55 miles per hour in "2" range - transmission may overheat.

If you're going up a very steep hill or going down a steep hill, shift to "1" range, also for "engine braking" at low speeds (25 mph or less).

### *Caution*

Do not exceed 25 miles per hour in "1" range - transmission may overheat.

#### 4-13. ROCKING THE COACH

If the motor coach becomes stuck in snow, sand, or mud, it can often be moved by a rocking motion. To accomplish this, move the range selector rhythmically between "D" and "R."

### *Caution*

Avoid racing the engine or spinning the wheels. Prolonged efforts to free a stuck motor coach may result in overheating and transmission failure.

#### 4-14. PASSING ACCELERATION

To obtain rapid acceleration at speeds below 30 mph, depress the accelerator briskly to the floor. This shifts the transmission to a lower gear. It will shift up again when foot pressure is released. Any time an engine lugging condition is encountered, manually downshift the transmission to obtain rapid acceleration. After the desired speed has been reached, manually shift the transmission into "D" range.

#### 4-15. HOLDING ON AN UPGRADE

The coach should be held on an upgrade only by using the foot brake or parking brake and the "P" (park) position of the range selector lever. Using a drive gear to hold on an upgrade can cause the engine and transmission to become overheated. Do not idle the engine for more than 1 minute with transmission in gear. Longer periods of idling,

while in gear, can cause overheating of engine.

#### 4-16. REFUELING

The fuel tank filler tube is positioned on the left side of the coach behind a key-locked access door. The engine is designed to run on low-lead gasoline. Most low-lead gasolines can be used under normal operating conditions. The use of completely lead free gasolines is not recommended (See par. 4-27f).

### *Warning*

Make certain LPG valve is closed before refueling. See Section 5.

#### 4-17. TOWING

Tow hooks at the front of the coach are provided to tow the coach should a breakdown occur. These hooks are located under the frame in line with the driver's door and are the ONLY points from which the coach can be towed.

### *Caution*

DO NOT allow any tow facility to wrap chains or ropes around front or rear bumpers as energy absorbers might be damaged. DO NOT lift coach to tow.

a. Towing With Transmission Inoperative. If transmission is inoperative, tow coach only after disconnecting the propeller shaft at the differential. Tie disconnected end of propeller shaft securely to frame.

b. Towing With Transmission Operative. The coach may be towed safely in "N" (neutral) at a speed less than 30 mph for distances up to 15 miles. Because the transmission receives lubrication only when the engine is running, disconnect propeller shaft (par. a above) if coach is to be towed more than 15 miles.

#### 4-18. ELECTRICAL SYSTEM

There are three electrical systems in your motor coach: a 12-volt automotive engine-ignition and exterior light system with driver's instruments and control lights; a 12-volt interior lighting system; and a 110-volt lighting system. This section deals only with the 12-volt automotive system (fig. 4-12). See Section 5 for interior 12-volt and 110-volt lighting systems.

a. Engine Ignition. The engine in your coach is equipped with a 12-volt electronic ignition system, which consists of two separate circuits - a low voltage (primary) circuit and a high voltage (secondary) circuit. The low voltage circuit is made up of the automotive battery (in engine compartment); dual ballast resistor and ignition coil, toothed reluctor, and magnetic pickup (part of engine distributor); starting-ignition switch and alternator indicator (on driver's instrument panel) the electronic control unit and the motor coach frame and wiring. The high voltage circuit includes the ignition coil secondary; the distributor cap and rotor (part of engine distributor); the spark plug cables; spark plugs; and the motor frame.

b. Automotive Battery. The 12-volt automotive battery mounted in the engine compartment supplies current to the low voltage primary circuit for engine ignition and also powers the exterior lights and driver's instruments through the starting-ignition switch. Powered directly from the battery are the horn, hazard lights, cigar lighter, and air conditioner condenser circuits. The automotive electrical system charges both the automotive and domestic batteries.

### *Caution*

Do not quick charge battery. Charge rate should not exceed 8 amp/hour.

c. Ignition Switch. The ignition switch mounted on the driver's instrument panel (fig. 4-7) is a four-position switch: "ACCY," "OFF," "IGN," and "START." Powered from the "ACCY" position are: the front-heater cooler and rear air conditioning blowers, and instrument lights. Powered from the "IGN" position are: the headlights, park-turn signal lights, and stop tail lights. Powered from the "START" position is the engine starting circuit. All circuits are protected by fuses as indicated in paragraph d below. See Section 6 for Automotive Light Bulb Listing.

d. Fuses (fig. 4-13). The automotive electrical circuits are protected from overloads by fuses which form an integral part of each circuit. All fuses, except the backup light circuit fuse, are mounted on a panel under the driver's instrument panel. The backup light fuse is mounted on the starter relay panel in the engine compartment. Figure 4-13 indicates fuse capacity and identification. This information is also contained on the inside of the fuse panel cover.

## 4-19. LIGHTS (fig. 4-14)

The automotive electrical system powers all the exterior lights and instrument panel lights.

a. Headlights. Your coach is equipped with dual sealed beam headlights; low beam and high beam. The outboard headlights contain low and high beam elements and the inboard lights contain a single high beam element. Keep headlights clean and free of dirt for complete effectiveness. It is recommended that when driving during daylight hours on two-way two-lane highways you turn on the headlights for your safety.

b. High Beam Foot Switch. This switch is located to the left of the steering column. Activate switch with your foot to turn high beams on or off.

c. Park-Turn Signal Light. Located on front of coach, park-turn signal lights contain a dual element bulb and an amber lens. When parked, pull light switch to first position and normal intensity element will go ON. The high intensity element operates when making a turn or when hazard switch is in "ON" position.

d. Rear Lights. The rear lights - stop, turn, tail, and back-up - are horizontally mounted and recessed in the coach body. With light switch in first or second position, taillights will go ON. The back-up lights operate when transmission range selector lever is placed in "R" (reverse). Stop lights go ON when brake pedal is depressed and the turn signal lights go ON when indicator lever on steering wheel is activated.

e. License Plate Light-Rear. License plate light is a single bulb white lens over the rear license plate and is lit when main light switch is in first or second position.

f. Running Lights-Front and Rear. Located on the lower side panels, running lights go ON when light switch is pulled to first or second position. Each running light is equipped with a reflex lens which reflects light to identify the coach. Front light has an amber lens; rear has a red lens.

g. Clearance-Identification Lights - Front and Rear Roof. Clearance lights are mounted at each roof corner and the identification lights are in the middle (set of three) at front and rear of coach. All the front lights are equipped with an amber lens and the rear lights have a red lens. All clearance and identification lights go ON when light switch is pulled to first or second position.







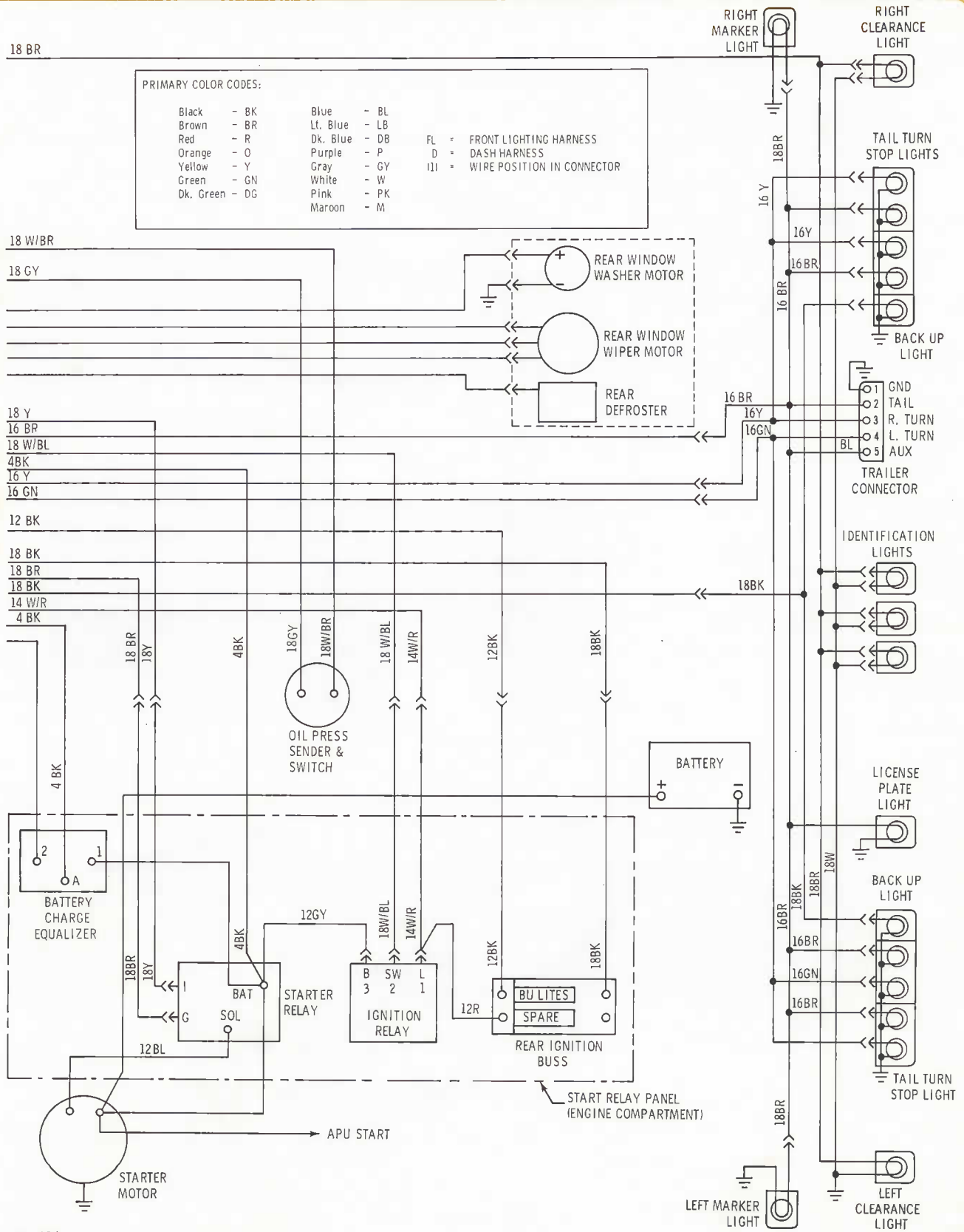

SD-404

Figure 4-12. Automotive Wiring Diagram (Sheet 4 of 4)

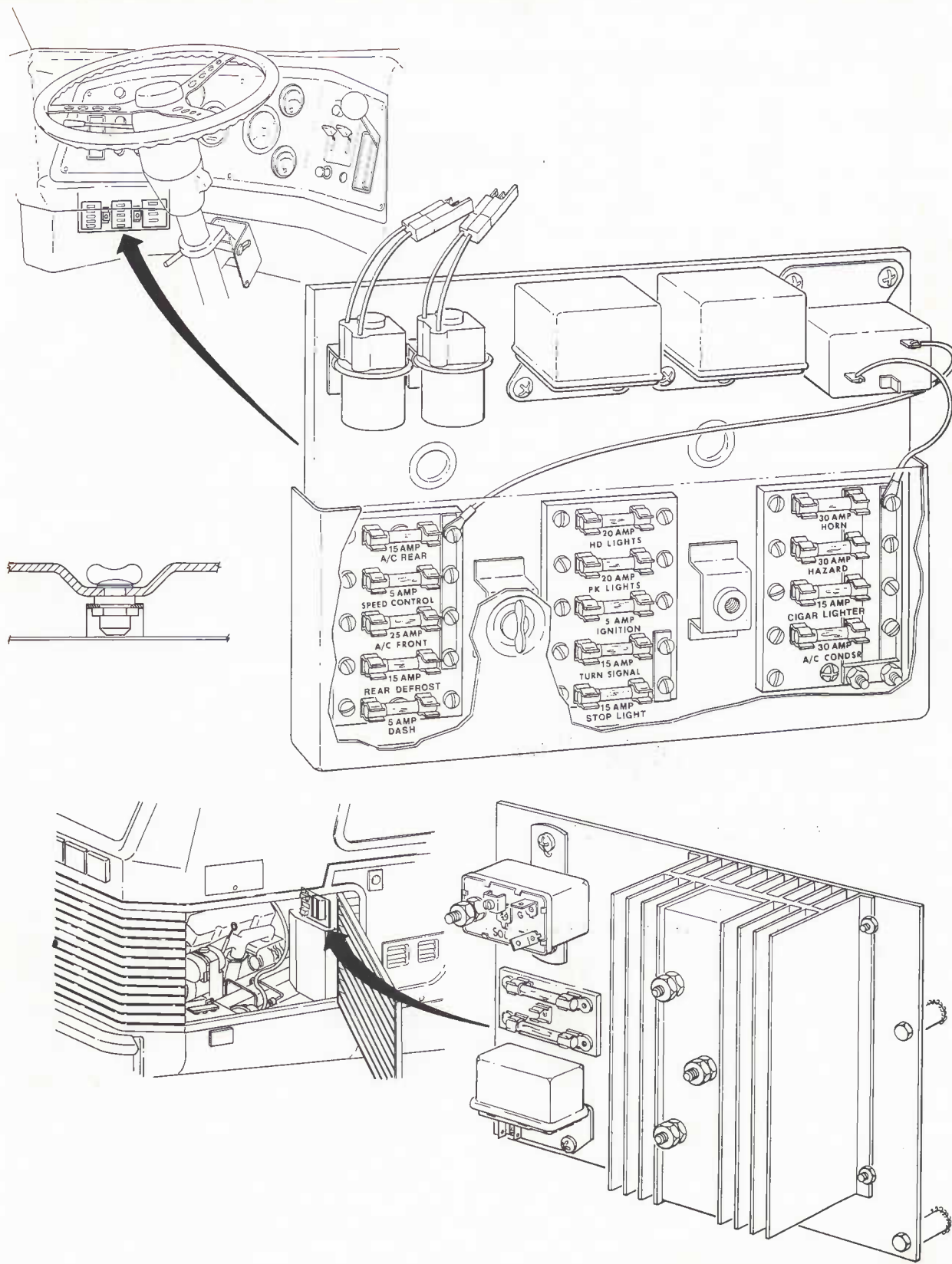
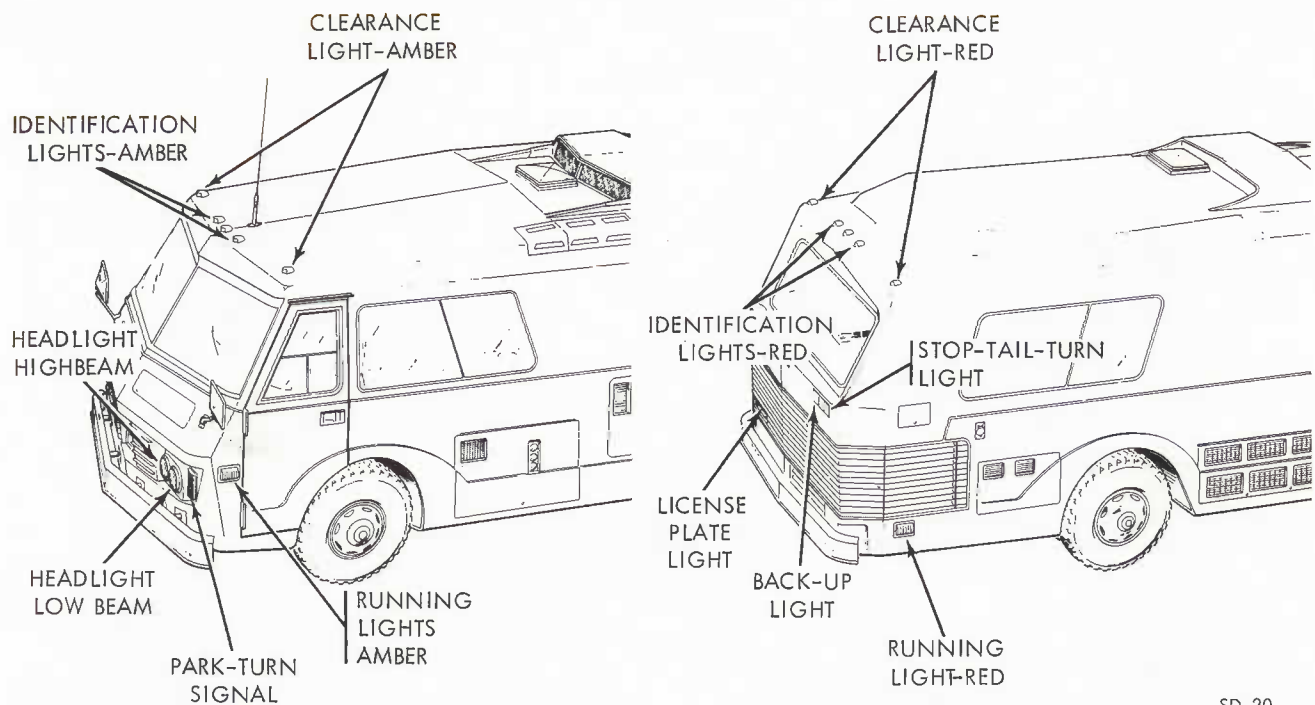

Figure 4-13. Electrical Fuses

SD-370



SD-20

Figure 4-14. Exterior Lights Locator Diagram

#### 4-20. AUTOMOTIVE HEATING-AIR CONDITIONING SYSTEM (fig. 4-15)

The air in your coach is comfort-conditioned by a combination heating-cooling system with some common components and controls.

a. Heating System. A hot water system pumps engine water through a heater-cooler unit at the front of the coach. Warm air is then blown into the coach interior through ducts and openings in the heater-cooler unit. Controls for the heater-defroster system are on the driver's instrument panel.

b. Air Conditioning System. The air conditioning system for driver and passenger comfort consists of a front and rear mounted unit with separate controls. Controls for the front air conditioner unit are on the driver's instrument panel. The rear air conditioning unit, mounted either in the center

of the rear bedroom panel or in the center of the right bedroom panel, has its own integral controls (fig. 4-17). When operating the heating-air conditioning system, make sure windows, doors, and roof vents are closed. The heating-air conditioning system will automatically adjust the coach interior temperature. A heating-air conditioning flow diagram, is provided in figure 4-15.

### *Warning*

The entire automotive air conditioning system, including the compressor, is under constant pressure. NEVER attempt to disconnect a hose, remove an oil plug or internally service the system. REFER ALL SERVICING TO AN FMC OR THERMO KING DEALER.

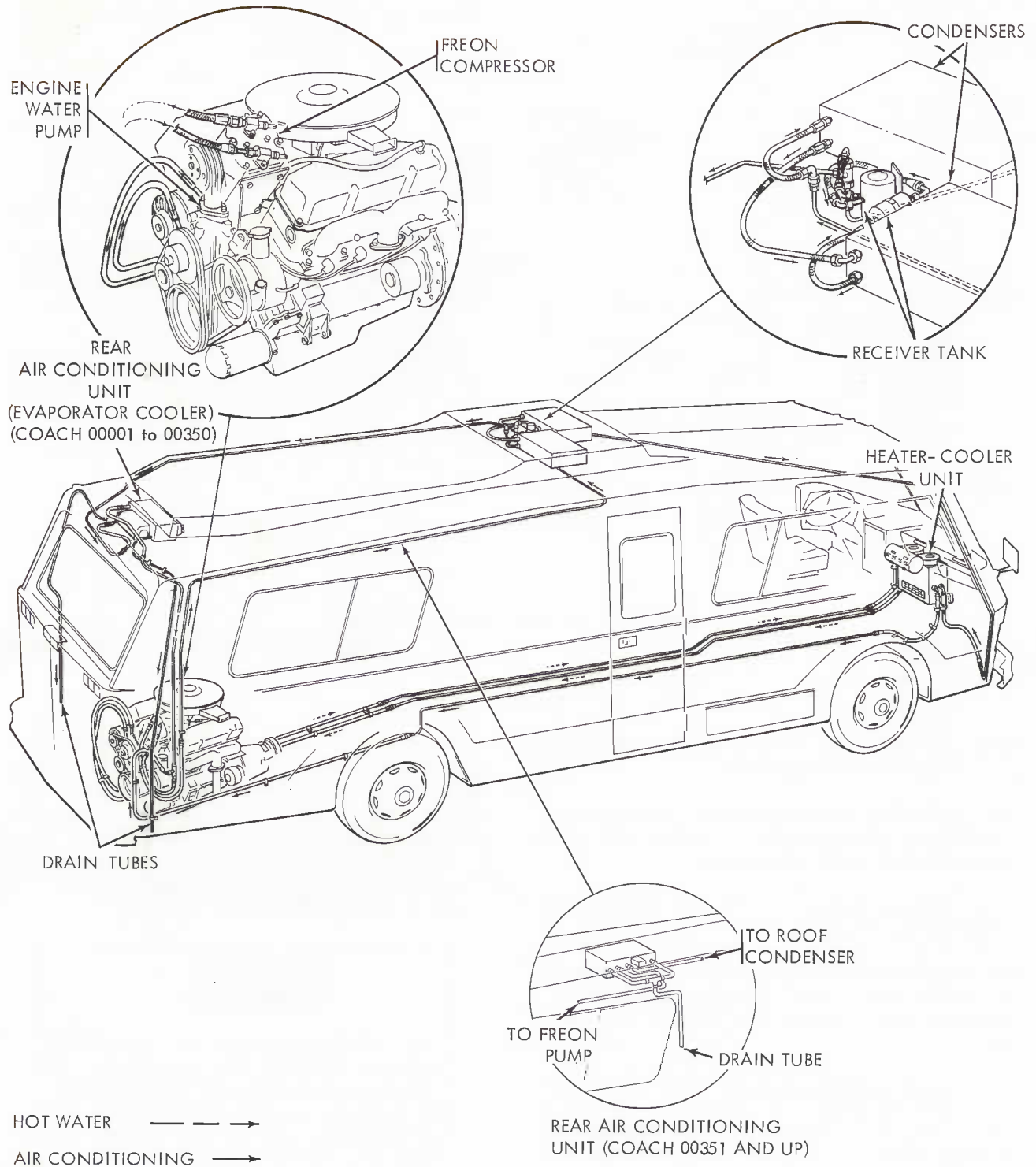

SD-373

Figure 4-15. Automotive Heating-Air Conditioning

## 4-21. HEATER DEFROSTER OPERATION

To operate heater: bring engine up to operating temperature (about 180°F), set SELECT lever to "HEAT," HEATER lever to "HIGH," and turn BLOWER knob to "LOW," "MED," or "HIGH" as desired. Blower will force heated air into driver's and passenger compartments to heat coach interior. To defrost windshield, move SELECT lever to "DEF" and blower will force heated air across windshield.

## 4-22. FRONT AUTOMOTIVE AIR CONDITIONING

Controls for the front AC are the same as the heater/defroster system. To operate: move select lever to "AC," heater lever to "OFF," then turn blower knob to "LOW," "MED," or "HIGH" as desired. Unit will automatically supply cool air when blower is turned on.

Have the air conditioning checked by a qualified refrigerant technician prior to the summer season or expected heavy usage.

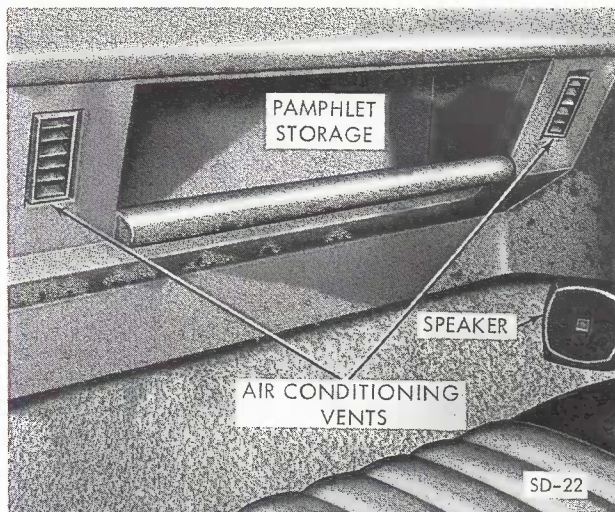
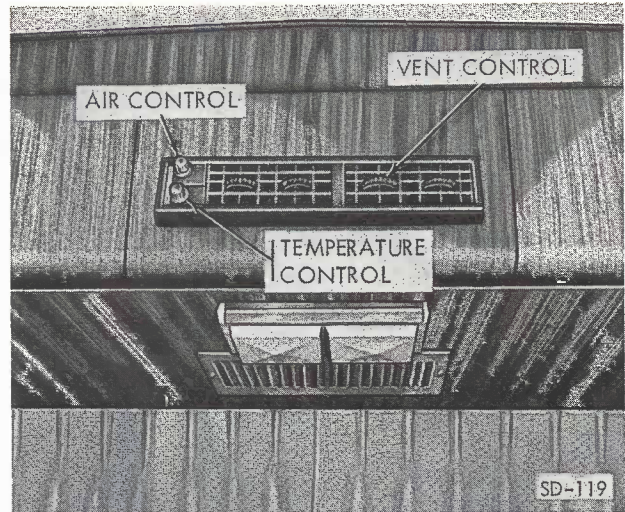

Figure 4-16. Front Air Conditioning Outlets

## 4-23. REAR AUTOMOTIVE AIR CONDITIONING (fig. 4-17)

To operate: turn air control knob to "HIGH," set temp control knob to "COLDER." Direct the air flow "UP" or "DOWN" and "LEFT" or "RIGHT" for your individual comfort by turning vent controls.



MOUNTED EITHER IN REAR OR SIDE BEDROOM PANEL

Figure 4-17. Rear Automotive Air Conditioning Outlets

## 4-24. TIRES AND WHEELS

a. Tires and Wheels. Coach wheels are truck-size tires, which are heavy and require special tools for proper tightening of studs; we recommend that owners change tires only when no other service facilities are available. It is possible to remove one of the dual rear wheels for use on the front should one of those fail. Remove the rear wheel from the same side of the coach as the failed wheel by following the jacking instructions (par. b below) for replacing a rear wheel. The wheel removed from the rear may be mounted on the front in the same manner as if it were a spare. It is possible to drive the coach at low speed in this condition until you are able to reach a service station to have the flat tire repaired.

### *Caution*

Do not exceed 25 mph, since driving in excess of 25 mph may overheat the single rear tire and cause a blow-out.

Keep wheels tight on their hubs by applying proper torque (300-350 ft-lb, lubed) to all wheel nuts.

Proper balance of the wheels and tires and alignment of the front wheels are essential to long tire life.

Pay particular attention to the condition of the tires. If given reasonable care, the tires should give you many thousands of miles of trouble-free service. But if abused, or overloaded, the tires may fail prematurely.

Check the tire pressures regularly with a truck-type air pressure gauge - once a week is not too often. Keep tires inflated to pressure recommended in Section 6. Always make sure the valve caps are tight.

Inspect tires at least once a month and remove any foreign objects caught in the treads.

**Warning**

Do not attempt to dismount a tire from a rim or remount it. This service should be performed by a tire service station. A safety hazard exists for an inexperienced person who dismounts or remounts a tire.

b. Jacking. To change a flat tire, place jack squarely under frame jacking points as indicated in figure 4-18 and lift coach. Remove wheel cover by prying with a wide blade screwdriver or similar tool. Loosen all wheel nuts and then raise coach until tire is clear of ground.

**NOTE**

If you plan to go off the main tourist routes, take along a short board for supporting the base of the jack should you have to change a tire in soft or sandy soil.

c. Changing a Wheel. Each coach is supplied with a heavy-duty jack stowed in forward compartment on right side. We recommend that only an approved jack be used to raise the motor coach. (Fig. 4-18.)

Turn off the engine and set the parking brake. Block both front and back of the wheel diagonally opposite the wheel to be removed.

**Caution**

The jack is designed for use as a tool for changing tires only. We recommend that you do not use the tire jack to lift the coach for service purposes. Jack coach only at designated points as shown in figure 4-18.

(1) Front Wheel. Place jack on a firm base and adjust its height until it just contacts jacking point on underside of coach near wheel to be removed. Raise jack just enough to take some of the weight off the wheel. DO NOT raise the tire off the ground at this time. With a wheel-nut wrench loosen, but do not remove the wheel nuts. Resume jacking coach until jack stand fits under the jacking point (fig. 4-18). Lower coach onto jack stand. Remove jack and unscrew mechanical extension from jack, then reinsert jack under coach. Raise coach until tire is about 1 inch above ground. Then raise jack stand to contact jacking point and lower jack so coach is supported by both jack and stand. Remove the nuts and the wheel. Place wheel on the coach and torque wheel nuts with wheel off the ground. Remove jack and stand and lower wheel to ground. Tighten the wheel nuts. Stop at a service station as soon as possible and have attendant check wheel nuts for proper torque (300-350 ft. lb).

(2) Rear Wheel Single. Failure of one of the dual wheel tires does not necessitate removing the wheel on the road. However, the coach should not be driven in excess of 25 mph until it is repaired. Driving in excess of 25 mph may destroy the flat tire, overheat the remaining tire and cause a blow-out.

(3) Rear Wheel Dual. When installing dual wheels, make sure they are mounted properly to prevent shearing of the wheel studs. Both wheels on same side must be off the ground (not resting on inner dual) to minimize the possibility of loose wheels after correct mounting torque is applied.

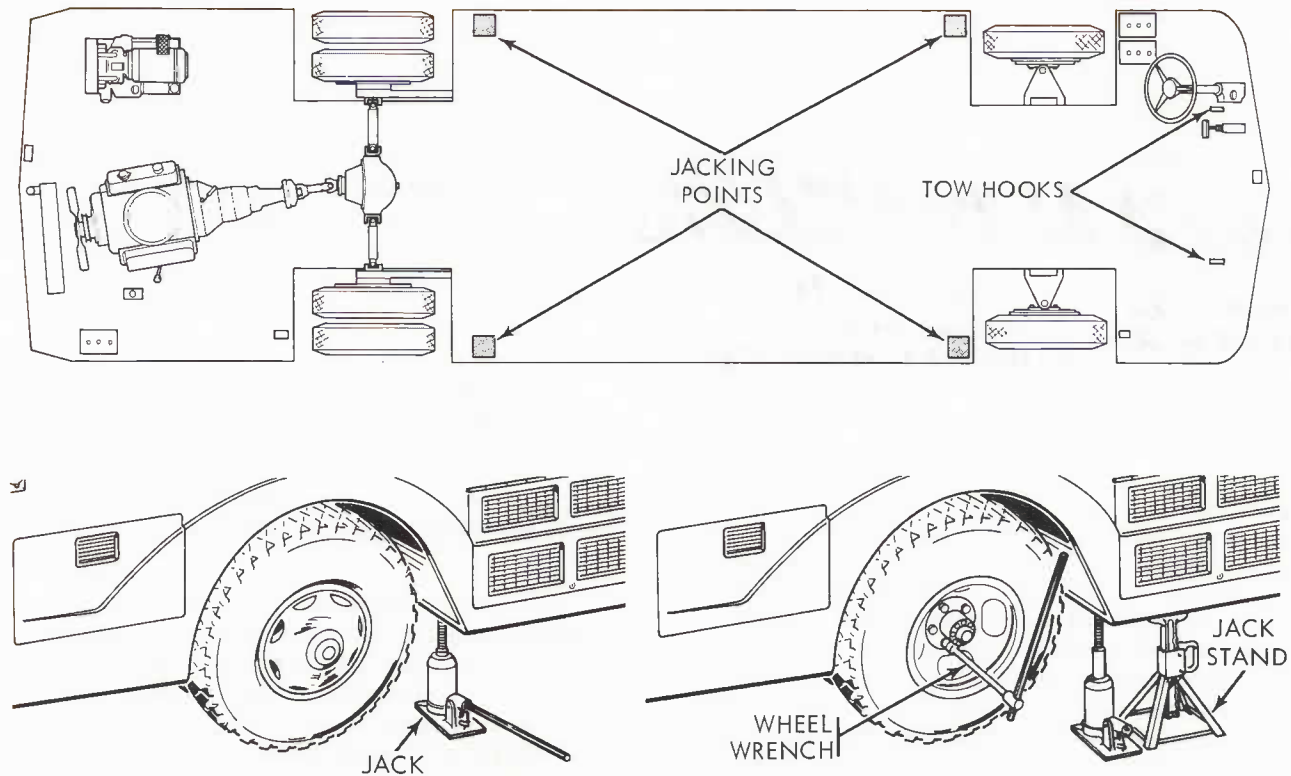

SD-374

Figure 4-18. Jacking Points

**Warning**

We recommend you obtain road service whenever possible and only attempt tire changing under emergency conditions with close adherence to the instructions.

(4) Wheel Nuts. To eliminate the possibility of the wheel studs being sheared or the bolt holes in the wheels becoming elongated, all wheel nuts should be tightened at frequent intervals. This is especially important during the first few hundred miles of operation to allow the wheel nuts to become properly set. On the rear dual wheels, the nuts should be checked at intervals of 100, 500, and 1,000 miles on a new coach and thereafter every 2,000 miles. After reinstalling dual wheels, be sure the nuts are checked at 100 and 500 mile intervals and thereafter every 2,000 miles. All nuts should first be seated firmly against the wheel. Then the nuts should be serviced by tightening the nut opposite to the previously tightened nut.

d. Tire Rotation (figure 4-18). Periodic rotation of the tires on your coach should be done only if tires are wearing unevenly. It is recommended that you rotate your tires in a manner that will even out the wear. It is not necessary to remove the tire from the wheel, just shift the complete wheel and tire. The rear dual tires should be matched for wear to prevent overloading one tire in a set. Under-inflation wear can be prevented by maintaining recommended tire pressure. It is recommended that you check with a Michelin Dealer when rotating tires to correct uneven wear.

e. Tire and Wheel Balance. Because of the possible high operating speeds proper tire and wheel balance is an important factor in correct and safe performance of your coach. Consult your nearest authorized FMC Service Center at the first sign of erratic wheel action or abnormal vibration so the wheel and tire balance may be inspected and corrected, if necessary with proper equipment.

f. Wheel Alignment. To provide the desired steering qualities and long tire life, the front wheels must be properly aligned with the road. Wheel toe-in adjustments are provided, but should only be made with the proper aligning gauges and adjustment know-how. It is recommended that this work be done only by your authorized FMC Service Center.

4-25. LUBRICATION AND MAINTENANCE (fig. 4-19)

CAMBER 1/2°  
CASTER 2+

TOE IN 1/4" OUT.  
BOTH SIDES  
DO NOT JACK UP!

Lubrication and maintenance services for your FMC motor coach detailed in the following paragraphs are recommended to insure you of maximum protection under all types of driving conditions. It is very important that these services be performed at the intervals indicated to extend maximum life of each component and for a pleasant and trouble-free motor trip. To accommodate owners who accumulate limited mileage, maintenance intervals are specified in both mileage and time intervals where appropriate. A Periodic Maintenance Services Chart (fig. 4-19) is provided to cover all lubrication and services that must be performed at specified intervals. This chart can be removed from this manual for use by a service station attendant. Make sure attendant checks all points and uses only recommended lubricants and fluids.

a. Lubrication. The Periodic Maintenance Services Chart will guide service personnel in selecting the proper lubricants and using them correctly. Please note that the information on the chart applies to NORMAL OPERATING CONDITIONS ONLY. If you operate your motor coach under conditions of extreme heat or over dusty unimproved roads, increase the frequency of the basic recommendation. Get into the habit of performing a periodic and comprehensive lubrication and maintenance schedule based on recommendations contained herein. Capacities for various components will also be found in the Periodic Maintenance Services Chart, figure 4-19.

(1) Engine Oil (EO). The SAE grade number indicates engine oil viscosity or consistency; for example, SAE30 is a single viscosity oil. Some engine oils are multiple viscosity, such as SAE10W-30, with a low viscosity when cold and increasing viscosity as the engine approaches operating temperature. References to API engine oil classification designating engine oil quality levels, as defined by both the old and new API engine oil classification system will be common during conversion

to the new designations for some time to come. For example, reference to "MS" (old designation) and "SE", or "CC" (new designations), may both appear on many engine oil containers. Only oils of "SE," or "CC" quality levels in the new system (with or without additional reference to designations in the old system) or oils with the old classification "For Service MS," should be used in the coach engine. Use only oils bearing the aforementioned API classification designations with a viscosity rating suitable to temperature conditions as follows:

(2) Lubricant-Multi-Purpose (MG). A semi-solid lubricant usually specified for universal joints and wheel bearings bears the NLG1 designation. These are further classified by Grade, such as 1, 2, 3, etc. Use this lubricant for the coach propeller shafts and wheel bearings in the Grade 2 classification.

(3) Gear Lubricant (GL). A multipurpose lubricant for heavy-duty axle and differential gears. Classified by SAE number which indicates the viscosity or consistency of the lubricant. Use this lubricant in the coach differential: SAE 140, GL-4 or GL-5, for all temperatures.

(4) Automatic Transmission Fluid (AT). A special fluid developed especially for automatic transmissions. Use only fluids labeled "DEXRON" Automatic Transmission Fluid" for all temperature ranges. This fluid is used in the coach transmission and also in the power steering unit.

(5) Brake Fluid (BF). A heavy-duty hydraulic brake fluid conforming to SAE J1703 specifications. Hydraulic brake fluid not clearly identified as meeting these specifications should not be used. Approved brake fluid is a chemically balanced high-quality substance having a wide temperature range so that it flows at low temperatures and does not vaporize at high temperatures. Accept no substitutes.

b. Battery Care. Check battery water level every 2 months, more often in hot weather or on long trips. DO NOT OVERFILL. Proper level is up to the split-ring. Use distilled water whenever possible. If water is added during freezing weather, drive coach several miles to mix electrolyte and prevent battery damage due to freezing. Automotive battery should be clamped securely in engine compartment, domestic batteries secure in mount under driver's floorboard, and cable clamps tight on their terminal posts. Neutralize any corrosion by washing with a solution of baking soda and water.



## PERIODIC MAINTENANCE SERVICES CHART – KEY

FREQUENCY SYMBOLS	APPLICATION	LUBRICANT OR SERVICE	MAXIMUM CAPACITY
2-every 2,000 miles or 3 months	*Engine emission Control Items	Inspect and clean See table 4-2	
4-every 4,000 miles or 6 months	Brake Master Cylinder	BF-High Temperature brake fluid	1 U.S. Pints 3/4 IMP Pints
	Differential	GL-Multipurpose Lubricant	2 U.S. Gallons 1-3/4 IMP Gallons
	* Engine Air Cleaner Element	Clean or Replace In dusty areas clean element daily.	
	Transmission Oil Check	AT-Dexron Automatic Transmission Fluid	18 U.S. Pints 15 IMP Pints
	* Crankcase Ventilation System	Check PCV valve, cleaner hoses, and carb choke for proper operation	
	* Engine Oil Drain & Fill	EO-Engine Oil designated "MS", "CC", or "SE"	6 U.S. Quarts (1) 5 IMP Quarts (1)
	Power Steering Reservoir	AT-Dexron Automatic transmission fluid Inspect and Add	4 U.S. Quarts 3 IMP Quarts
	Engine Water Pump (2)	MG-Multipurpose grease, NLG1, grade 2EP	
12-12,000 miles or annually	*Engine Fuel Filter	Change filter element	
	Propeller shafts	MG-Multipurpose NLG1, grade 2EP	
20-every 20,000 miles or 2 years	Transmission Oil Drain & Fill (3)	AT-Dexron Automatic transmission fluid	18 U.S. Pints 15 IMP Pints
S-as specified	Automotive and Domestic batteries	Check level Add distilled water	
	Brake Booster Air Cleaner	Change air cleaner filter on Front and Rear Boosters	
	* Engine Oil Filter	EO-Engine Oil designated "MS", "CC", or "SE" Inspect and change	1 U.S. Quart 3/4 IMP Quart
	* Radiator Coolant	Check coolant level. Use mixture of 50% ethylene glycol and water	33-1/2 U.S. Quarts 27 IMP Quarts
	Front Spring U Bolt Nuts	Check tightness. Torque to 171 – 189 foot pounds	
	Wheel Bearings	MG-Multipurpose grease, NLG1, grade 2 EP	
	Windshield Washer Reservoirs	Windshield solvent Inspect and add	1 U.S. Quart 3/4 IMP Quart
	Auxiliary Power Unit (APU)	EO-Engine Oil Designated "MS", "CC", or "SE"	4 U.S. Quarts (4) 3 IMP Quarts (4)

\* These are emission-related; see table 4-2 for further information.

(1) When filter is replaced, add 1 U.S. (3/4 IMP) quart.

(2) Use low pressure grease gun.

(3) Initial change at 32,000 miles under normal operating conditions; 20,000 mile intervals thereafter.

(4) When filter is replaced, add 1/2 U.S. (3/8 IMP) quart.

## PERIODIC MAINTENANCE SERVICES NOTES

1. Brake Master Cylinder. Fluid should be checked each 4,000 miles or 6 months of operation. Replenish with Heavy Duty Hydraulic Brake Fluid (BF) conforming to current SAE J1703 specification. Brake fluids not clearly identified with these specifications should not be used. Normal brake fluid level is 1/4 inch below filler cap. Check systems for leaks if fluid is frequently low.
2. Windshield Washer Reservoir. Fluid should be checked before starting on a trip and at each lubrication and oil change period. Fill with good grade of windshield solvent and in cold weather use an antifreeze specifically made for washer use.
3. Brake Booster Air Cleaner. Replace cartridge every second oil change or if operating in dusty areas every 4,000 miles or 6 months.
4. Wheel Bearings Front and Rear. Once every 12,000 miles or annually, remove hub and inspect bearings. If grease is in poor condition, insufficient quantity, or if vehicle has been operated under severe conditions, clean the bearings, races, and hub cavity thoroughly. Repack the bearings with multi-purpose Grease NLG1 Grade 2. NEVER ADD GREASE - RELUBRICATE COMPLETELY.
5. Engine Oil Drain. Change every 4,000 miles or 6 months under normal driving conditions. For abnormal service - such as short trips, prolonged and frequent idling, and dusty conditions - change oil every 2,000 miles or 3 months. Drain while engine is at normal operating temperature (185°F). Oil drains more completely when hot, and any foreign matter and contaminants will be removed with the oil.
6. Engine Oil Dipstick. Engine oil level should be checked each time you stop for fuel. The "FULL" mark indicates correct level of oil after engine has been standing for some time. When engine is running, oil level drops slightly as it fills up the oil passages and channels. Add a quart when oil falls below "ADD OIL" mark on dipstick. Never allow oil level to remain below the "ADD OIL" mark.
7. Automotive and Domestic Batteries. Check water level and bring up to split ring level each oil change. Check more frequently if operating in hot areas for substantial periods. Use distilled water whenever available.
8. Power Steering Reservoir. Check fluid level every 4,000 miles or 6 months or with each oil change. Start engine, turn steering wheel from stop-to-stop several times to expell air from system, then shut off engine. Wipe reservoir filler cap free of dirt, remove cap, check oil level. Add fluid if necessary. Use only approved DEXRON Automatic Transmission Fluid.
9. Engine Oil Filter. Replace filter every second oil change. Always replace with a Chrysler filter. If operating in dusty areas, replace oil filter cartridge more frequently, such as at each oil change. After replacement, operate engine for 5 minutes and check for oil leaks. Add enough oil to compensate for oil absorbed by a new filter.
10. Engine Water Pump. Every 4,000 miles or six months lubricate sparingly fitting located on water pump housing behind camshaft pulley with Multi-purpose Grease NLG1, Grade 2 EP. DO NOT USE A HIGH PRESSURE GREASE GUN ON THIS FITTING.
11. Radiator Fill and Level. Coolant should be checked before starting on a trip and at each lubrication and oil change period. Coolant should be within 3-1/2 inches of top of filler neck. Use a mixture of 50% ethylene glycol and water. Drain and flush system every 12,000 miles or annually. Discard old coolant.
12. Engine Fuel Filter. Replace every 12,000 miles or annually. Run engine and test for leaks.
13. Engine Oil Fill. Add oil if dipstick (Note 6) is at or below "ADD OIL" mark. Use only oils meeting API classification with a viscosity rating suitable to temperature conditions.  
  
Above +32 degrees F the preferred viscosity for your coach is SAE 40, then SAE 30, SAE10w-30, SAE 10w-40, SAE 10w-50, SAE 20w-40, or SAE 20w-50.  
  
As low as +10 degrees F the preferred viscosity for your coach is SAE 10w-40, then SAE 10w-50, SAE 20w-20.  
  
As low as -10 degrees F use SAE 15w-40, SAE 10w-30, SAE 10w-50, SAE 10w, SAE 5w-20, or SAE 5w-30.  
  
Below -10 degrees F use SAE 5w-30 or 5w-40.
14. Crankcase Clean Air Emission System. Check every 4,000 miles or 6 months, or more frequently if coach is used for short trip driving, and prolonged and frequent idling. Operate engine at idle and remove ventilator valve from rocker cover. If valve is NOT plugged, a hissing noise will be heard and a strong vacuum should be felt when you place your finger over valve inlet. Reinstall valve, then remove crankcase inlet air cleaner. Loosely hold a piece of stiff paper (parts tag) over opening in rocker cover. After about 1 minute, paper should be pulled against opening in rocker cover.  
  
Stop engine and remove ventilator valve from rocker cover. If valve is free, a clicking noise will be heard. If system meets the above tests, no further service is required. If not, replace ventilator valve with a new valve and recheck system. DO NOT ATTEMPT TO CLEAN THE OLD VALVE.  
  
Disconnect hose between carburetor air cleaner and crankcase inlet air cleaner (on valve cover). Inspect hose for blockage and clean if necessary. Remove crankcase inlet air cleaner and wash in kerosene or similar solvent. Wet the inlet air cleaner filter by inverting cleaner and filling with SAE 30 Engine Oil. Allow excess oil to drain through vent nipple at top of cleaner. Reinstall cleaner and connect hose.  
  
Upon recheck, if paper is not pulled against the opening in valve cover with noticeable force, clean ventilator hoses and passages in lower part of carburetor. Clean in a good grade of solvent and dry with compressed air.

15. Propeller Shafts. Lubricate every 12,000 miles or annually with Multipurpose Grease, NLG1 Grade 2 EP. Apply grease to fitting at each universal joint located on both sides of coach and on the transmission to differential shaft. Lubricate slip yokes with Molybdenum Disulfide Grease. DO NOT USE A HIGH PRESSURE GREASE GUN.
16. Air Cleaner Element and Carburetor Automatic Choke. Every 4,000 miles or 6 months, remove element and blow out dirt gently with an air hose. Direct air from the inside out, and keep nozzle 2 inches away from element to avoid damage. If element is saturated with oil for more than one-half its circumference, replace element and check Crankcase Clean Air Emission System. Clean metal container. Every 20,000 miles or 2 years, install a new element. Service air cleaner element more frequently (daily) if driving in severe conditions, such as dusty areas.  
To prevent the choke from sticking, apply a combustion chamber conditioner to choke shaft where it rotates in the air horn. Move choke shaft back and forth to distribute solvent. This will prevent formation of gum deposits on shaft which may restrict its movement. Apply same solvent to fast idle cam and pivot pin to remove dirt, oil, and other deposits which could cause sticking or erratic motion. Apply conditioner at least every 4,000 miles or 6 months.
17. Transmission Oil Dipstick. Check fluid level every 4,000 miles, 6 months, or every engine oil change. To check, start engine and bring transmission up to normal operating temperature. With parking brake ON and engine idling, move selector lever into each position ending in the "N" position. Remove dipstick; fluid level should be between "FULL" and "ADD ONE PINT" marks, but never above the "FULL" mark when engine is warmed up. Add or drain fluid to bring to proper level. Make certain cap is resealed properly on filler tube.
18. Transmission Drain and Fill. Under normal operation drain fluid at 32,000 miles. At same time, clean filter. When operating under severe service with heavy loads, trailer towing, or off highway, especially in hot weather, increase frequency of service to 20,000-mile intervals. To drain, place a container with a large opening under transmission oil pan. Loosen pan bolts and tap pan bolts at one corner to break pan loose and allow fluid to drain. Remove access plate from front of converter, remove drain plug and drain fluid. Install drain plug (torque to 100 inch-pounds) and install access plate. Remove and clean oil pan. Use a new gasket and install oil pan. Tighten pan screws to 150 inch-pounds. Add DEXRON Type Automatic Transmission Fluid through filler tube and check level as in Note 17.
19. Differential Drain and Fill. Every engine oil change, remove differential filler plug and check lubricant level. Add Multipurpose Gear Lubricant (SAE 140, GL-4 or GL-5) to bring level up to bottom of filler hole plug. DO NOT OVERFILL. Drain differential and refill prior to any anticipated temperature change or after every 32,000 miles of operation, whichever occurs first. In severe or abnormal operating conditions, change lubricant every 20,000 miles.
20. Front Spring. Check tightness of front spring U bolt attaching nuts within the first 500 miles of operation. Thereafter, check U bolt nuts each time coach is lubricated. Recommended torque is 171 to 189 foot-pounds.
21. Auxiliary Power Unit Dipstick. Every 8 operational hours, remove oil filler cap and check level on dipstick. Keep oil at "FULL" mark. NEVER operate APU with oil level below "LOW" mark. Replace cap tightly to prevent oil leakage. When adding oil between changes, always use same brand that is in crankcase. Never remove oil filler cap when APU is running.
22. Auxiliary Power Unit Governor Linkage. Every 50 operational hours, check governor linkage for free movement through its entire travel. Clean but DO NOT lubricate governor ball joints.
23. Auxiliary Power Unit Air Cleaner. Every 100 operational hours, remove paper element and clean by removing foam wrapper and tapping element against a flat surface to loosen dust and dirt. Blow out dirt from the clean to the dirty side, using LESS than 100 psi air pressure. If necessary, wash element and foam wrapper in a solution of warm water and mild detergent.  
  
Every 500 operational hours, change the cartridge. Remove wing screw and cover; install new cartridge and secure with wing screw and cover.
24. Auxiliary Power Unit Crankcase Oil and Filter. Every 100 operational hours, drain crankcase oil and refill with good quality heavy duty oil. If operating consistently at high temperatures (100°F and above), change oil every 50 operational hours. Use only oils meeting API designation MS, MS/DG, SE, or SE/CC. Use proper grade oil for the expected conditions.  
  
Above 90°F use SAE 50; 30° to 90°F use SAE 30; 0° to 30°F use SAE 10w-40, 5w-30; below 0°F use 5w-30.  
  
Every 200 operational hours, change the crankcase oil filter. Remove filter by turning counterclockwise using a filter wrench. Clean and wipe dry the drip pan below the filter. Install new filter and gasket and tighten finger tight 1/4 to 1/2 turn.
25. Auxiliary Power Unit Fuel Pump. Remove lower cover on fuel pump and clean screen in good grade of solvent.
26. Auxiliary Power Unit Spark Plugs. Check spark plug gap and set to 0.025 inch on both plugs.

## Caution

Do not quick charge battery. Charge rate should not exceed 8 amp/hour.

## Warning

Keep flame or sparks away from battery - explosive hydrogen gas may be present. Make sure vent caps are on securely before washing. Rinse with clear water.

**c. Severe Operating Conditions.** Severe operating conditions - such as driving for short distances of only a few miles at a time and at low speeds, pulling heavy load, off-highway operation and winter driving - require special maintenance attention. At low speeds for short miles, moisture will condense in the crankcase and form a sludge. Under these conditions, the engine does not become warm enough to expel the condensation through the crankcase ventilation system. Consequently, the engine oil should be changed about every 1,000 miles. Pulling a heavy load or off-highway operation places additional work on the transmission. Consequently, the transmission fluid should be drained and changed every 20,000 miles.

**d. Dusty Conditions.** Driving through dust-laden air greatly increases the problems of keeping abrasive materials out of the engine. Under these conditions, special attention should be given to the carburetor air cleaner and the crankcase ventilation system. Make sure these units are clean at all times. This will tend to reduce to a minimum the amount of abrasive material that may enter the engine. Consequently, the crankcase oil and oil filter cartridge should be changed more frequently. The frequency will depend upon the severity of dust conditions; therefore, no definite recommendations can be made.

**e. Alternator (fig. 4-20).** Alternator on coach does not require lubrication. It is recommended that the alternator-compressor drive belts be checked frequently for proper tension. Belts should not be worn or frayed. Proper alternator-compressor belt tension is 50 - 60 pounds measured on a belt tension gage. Tighten belt by inserting a pry bar between engine block and alternator, loosen alternator bolts, and move alternator until belts are tight. Tighten bolts securely against bracket.

**f. Power Steering Pump (fig. 4-20).** Check power steering pump belt frequently for proper tension. Belt should not be worn or frayed. Proper belt tension is 60 - 80 pounds measured on a belt tension gage. Tighten belt using a 1/2" socket in square hole top of bracket.

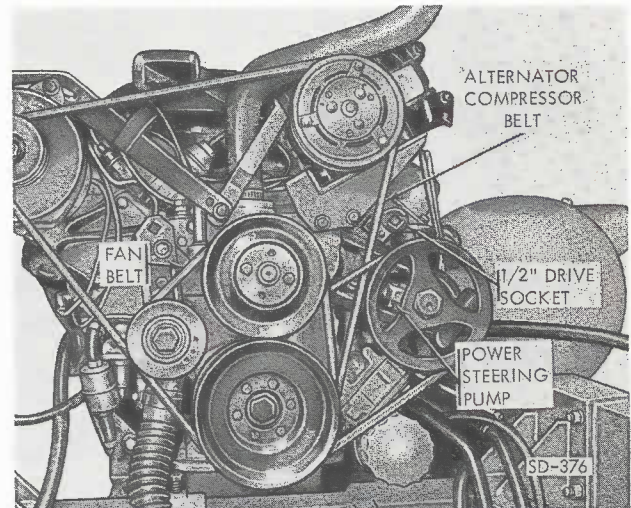

Figure 4-20. Belt Adjustment

## 4-26. FUEL SYSTEM (fig. 4-21)

The fuel system consists of a 60-gallon fuel tank (left rear of coach), fuel pump, fuel filter, carburetor, and fuel and vacuum lines. The tank is equipped with a filler neck cap, air vent, and a fuel gage sending unit. The sending unit measures amount of fuel in tank and relays this information to the fuel gage on the driver's instrument panel. The fuel tank supplies both the engine and auxiliary power unit (APU).

## Warning

Make certain LPG valve is closed before refueling. See Section 5.

**a. Carburetor Adjustments.** The carburetor is designed and calibrated to the proper mixture for most economical and efficient performance at all speeds while keeping air pollution to a minimum. If adjustments become necessary, they should be made only by a Dodge Recreational Vehicle Service Center or Chrysler Dealer with proper equipment. See Periodic Maintenance Services Chart, figure 4-19, for clean air servicing.

**b. Fuel Filter.** The fuel filter mounted on the engine removes any sediment or water that may enter the fuel tank. Filter is a replaceable element type and the element should be replaced every 12,000 miles, or 1 year, whichever occurs first. See Periodic Maintenance Services Chart, figure 4-19.

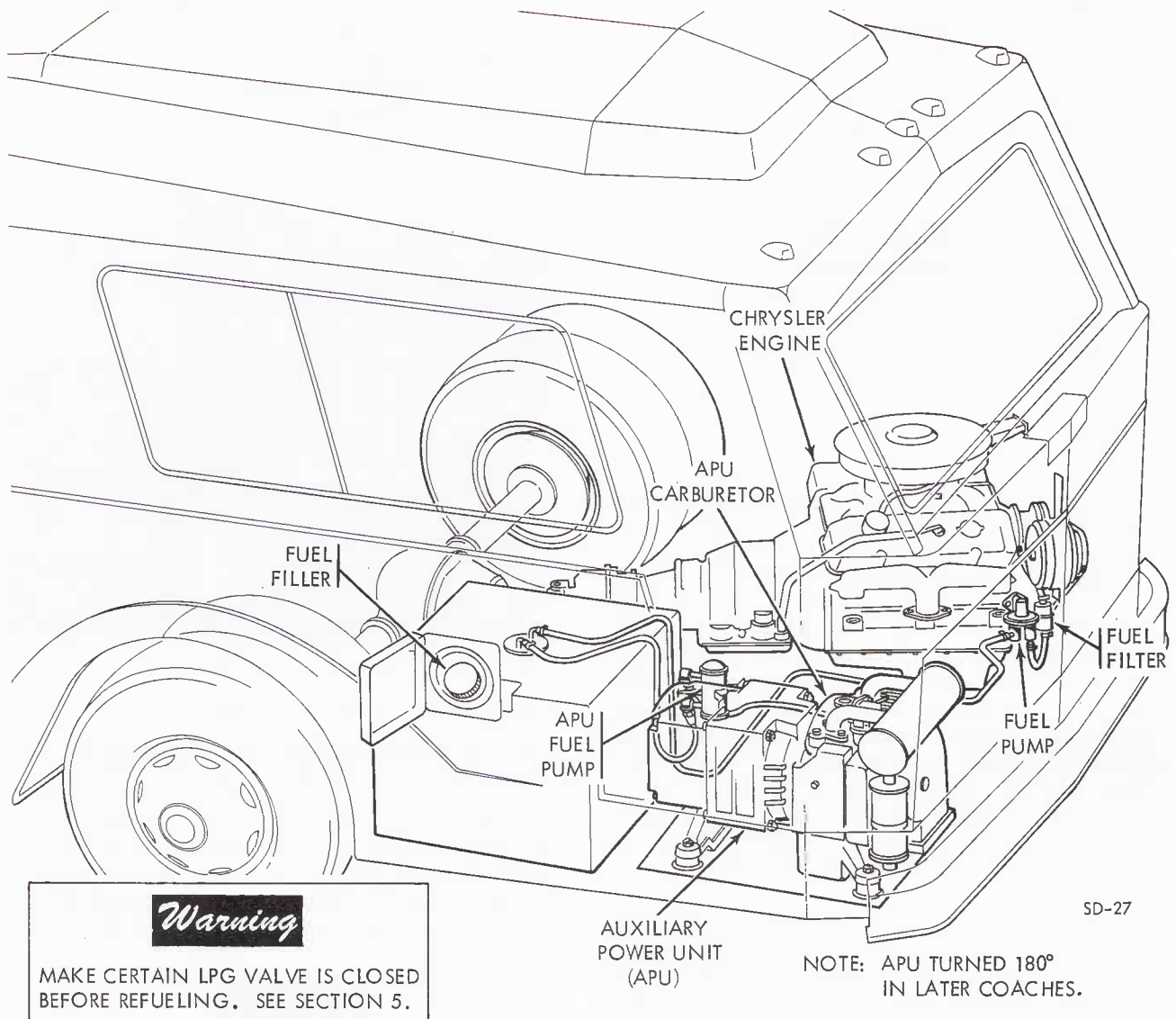

**Warning**  
 MAKE CERTAIN LPG VALVE IS CLOSED BEFORE REFUELING. SEE SECTION 5.

Figure 4-21. Fuel System Flow Diagram

4-27. CLEAN AIR EMISSION SYSTEM (fig. 4-22 and 4-23)

a. Federal Clean Air Act. The Federal Clean Air Act requires the vehicle manufacturer to furnish, with each new vehicle, such written instructions for the maintenance and use of the vehicle by the ultimate purchaser as are reasonable to assure the proper functioning of emission control devices and systems installed in the vehicle. The information appearing below is provided in compliance with the law.

b. Normal Coach Use. The emission control maintenance instructions contained herein are based on the assumption that your coach will be used as designed:

- . . . To carry passengers and camping equipment within the limitations indicated on the tire and rim plate on panel behind drivers seat.
- . . . To operate on reasonable road surfaces within legal operating limits.
- . . . To operate on a daily basis, as a general

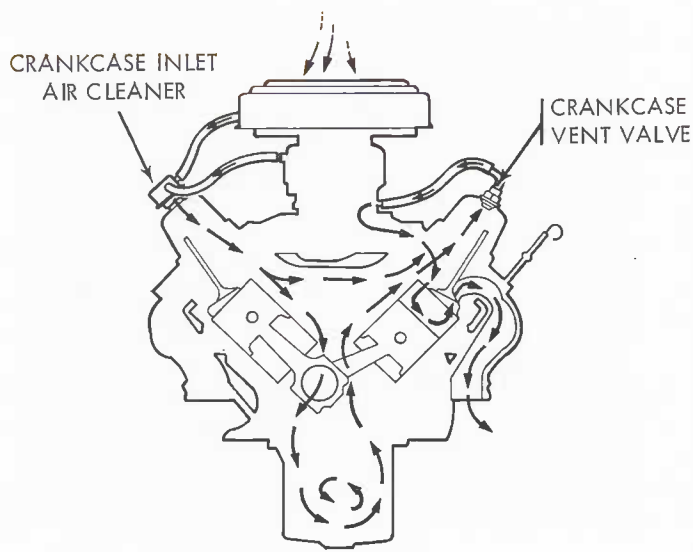

SD-28

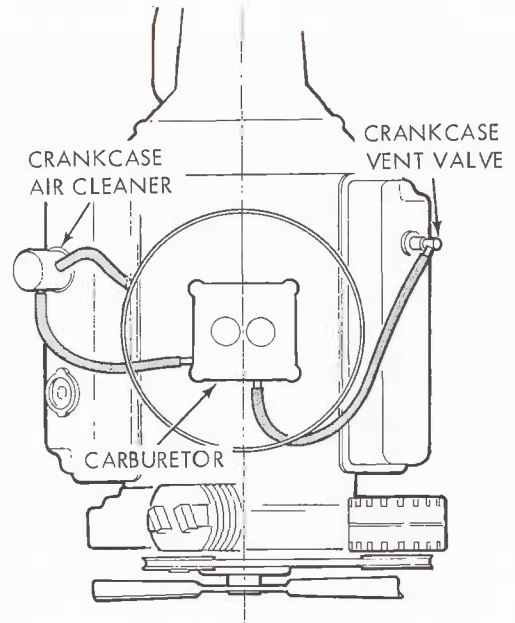

SD-375

Crankcase Air Cleaner and Vent Valve

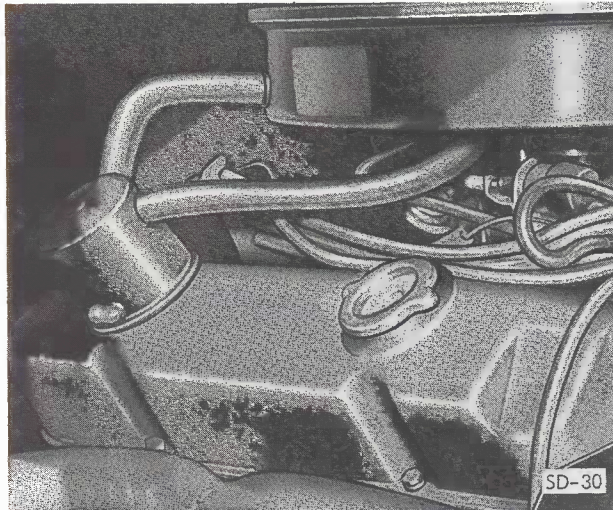

Crankcase Inlet Air Cleaner and Hoses

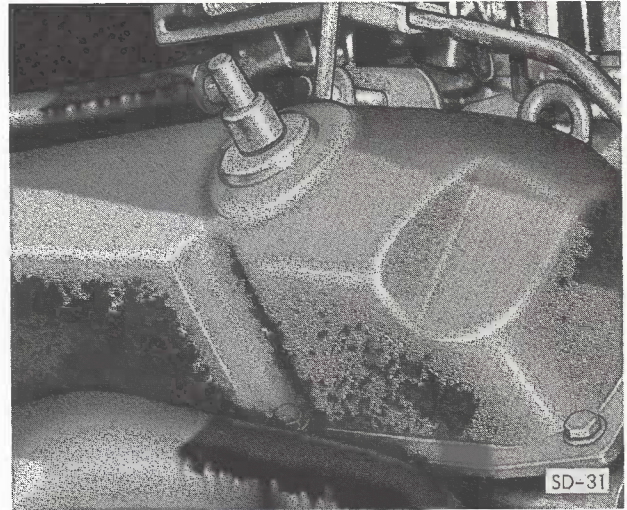

Ventilator Valve

Figure 4-22. Clean Air System

rule, for at least several miles.

- . . . To operate on low-lead gasoline (see par. f).
- . . . And to increase the frequency of maintenance if operating under unusual conditions.

c. Maintenance Source and Evidence. The required owner maintenance presented herein should be performed by a Dodge Recreational Vehicle

Service Center or any other qualified service outlet which regularly performs such services on gasoline internal combustion engines. You should retain receipts covering the performance of regular maintenance in the plastic case provided in each coach should questions arise concerning maintenance. These receipts and records should be transferred to each subsequent owner of this coach.

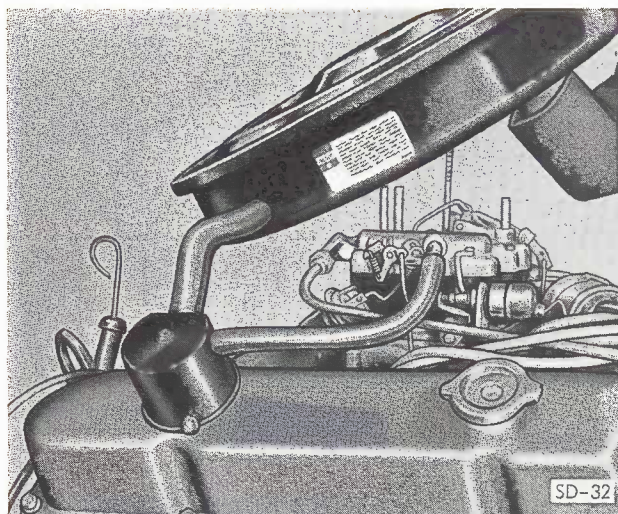

Ventilation Air Cleaner Hose Hook-Up

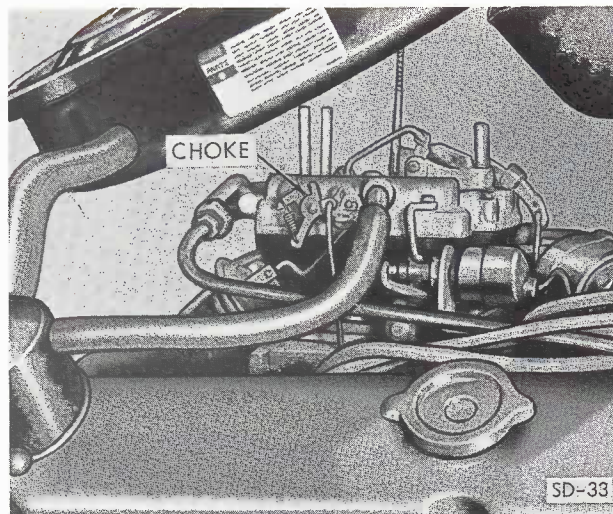

Carburetor Choke Shaft

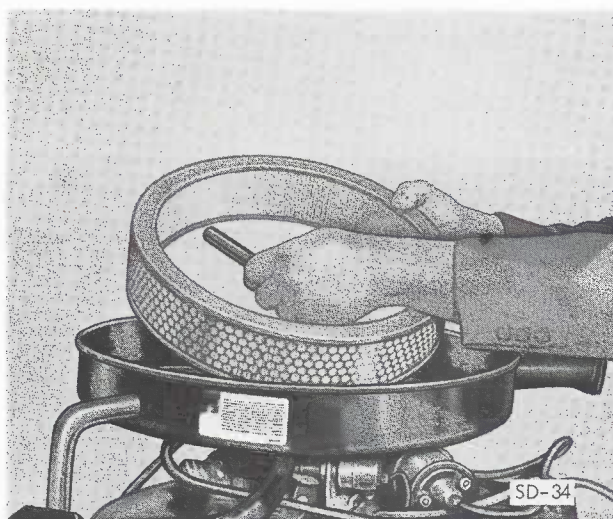

Air Cleaner Element

Figure 4-23. Clean Air System

d. Replacement Parts. The clean air emission control system was designed, built, and tested using genuine Chrysler Marine and Industrial Engine Division parts and the system is certified by the Chrysler Corporation as being in conformity with federal regulations implementing the Federal Clean Air Act. Accordingly, it is recommended that any replacement parts used for maintenance services or repair of emission control system be new, genuine, Chrysler engine parts. Use of replacement parts which are not of equivalent quality may impair the effectiveness of the system. Genuine parts are available from Chrysler and Dodge Recreational Vehicle Service Centers. If

other than genuine Chrysler parts are used for required maintenance of the emission control system, the owner should satisfy himself that such parts are warranted by their manufacturer to be equivalent to the Chrysler part in performance and durability.

**NOTE**

Genuine Chrysler part, when used in connection with FMC Recreational Vehicle Model 2900R, means parts manufactured by or for the Chrysler Marine and Industrial Engine Division for use on Chrysler marine and industrial engines and distributed by

Table 4-2. Owner's Emission Control Maintenance Services (1)

MAINTENANCE SERVICE	MAINTENANCE INTERVALS				SERVICE RECORD	
	2	4	12	20		
					Record date & mileage of emission control maintenance service and retain invoices.	
Air Cleaner Hoses		I	I	R		
Air Cleaner Element (3)	C	C	C	R	2=2,000 miles or 3 months	DATE <u>3/15/75</u> MILEAGE <u>3119</u>
Carburetor Choke and Fast Idle Cam	I	C	C	C		
Carburetor Passages		I	C	C	4=4,000 miles or 6 months	DATE <u>8/7/75</u> MILEAGE <u>6929</u>
Crankcase Inlet Air Cleaner	C	C	C	R		
Crankcase Ventilator Valve	I	I	I	R	12=12,000 miles or annually	DATE <u>9/1/76</u> MILEAGE <u>15993</u>
Drive Belts	I	I	I	I		
Engine Fuel Filter	I	I	R	R	20=20,000 miles or 2 years	DATE <u>5/1/78</u> MILEAGE <u>79100</u>
Engine Oil Drain	I	R	R	R		
Engine Oil Filter (2)	I	I	R	R		
Ignition Cables	I	I	I	I	30=30,000 miles or 3 years	DATE _____ MILEAGE _____
Ignition Timing and Idle Mixture	I	I	I	I		
Radiator Fill & Level	I	I	I	I	(2) Change engine oil filter every second oil change.	
					(3) Change element daily in dusty areas.	

KEY

C = Clean  
I = Inspect, correct/replace if necessary  
R = Replace

(1) To be performed by a qualified service technician. See Periodic Maintenance Services Chart, figure 4-19.

Chrysler, Dodge Recreational Vehicle Division, or FMC Recreational Vehicle Division Dealers and Service Centers.

e. Source of Emissions. During the combustion process that takes place in an internal combustion engine, some of the fuel fails to burn completely. The unburned fuel in the form of hydrocarbons is discharged into the engine crankcase or exhaust system. In addition to hydrocarbons, carbon monoxide and oxides of nitrogen are also formed during the combustion process. These are also discharged into the exhaust system.

f. Gasoline Improvements. An important advancement in air pollution has been the reduction in lead level or elimination of lead from some grades of gasoline. Your motor coach is designed to operate on low-lead gasoline. However, any gasoline with a minimum of 0.5 grams per gallon and having a minimum 91 research octane number or higher will satisfy the engine's octane requirements. You can also use a "certified octane number" of 89, or better, which is equal to the published 91 octane rating.

g. Positive Crankcase Ventilation. Your engine is equipped with a positive crankcase ventilation

system designed and carefully calibrated for proper carburetor mixture, and economical and efficient performance at all speeds while keeping air pollution to a minimum. If adjustment becomes necessary it should be done by an authorized Dodge Recreational Vehicle Service Center or Chrysler Dealer with proper equipment. A check of items affecting emission control (table 4-2) at the first oil change is important to provide for low emissions of hydrocarbons and carbon monoxide. Subsequent checks should be made every 12,000 miles or annually. These checks involve adjustment of engine idle speed, ignition timing, idle fuel mixture, and operational checks of crankcase ventilation valve and hoses. Climatic conditions, type of operation, wear, and contamination can affect these engine adjustments and proper functioning of the system. A frequent check for proper operation will not only contribute to the control of exhaust and engine emissions, but will improve performance and economy.

**h. Positive Crankcase Ventilation Operation.** The fully closed crankcase ventilation system operates by air drawn into the crankcase from the air cleaner and through the crankcase inlet air cleaner by means of a hose (fig. 4-22). Air circulates through the engine and is drawn out of the cylinder head cover by manifold vacuum into the combustion chambers and expelled with the exhaust gases. The system consists of a ventilator valve installed in the outlet vent of the valve cover (fig. 4-22), and a hose. The hose is connected between the ventilator valve and the lower part of the carburetor body. The valve regulates the flow of crankcase ventilation at various throttle positions and will operate effectively as long as normal maintenance is done. The valve and hose are subject to fouling with sludge and carbon formation because of the nature of the material carried by the ventilation system. A plugged vent system may in turn cause excessive engine crankcase sludge formation and may also cause rough or erratic engine idle or excessive oil leakage. The ventilation system should be cleaned every 6 months and the valve replaced every year in average service - more frequently if the coach is used extensively for short trips (driving less than 10 miles) with frequent idling, such as in city traffic.

#### 4-28. ENGINE TUNE-UP

Test specific gravity of coach battery (see Section 6). Add distilled water if necessary, clean and tighten battery connections. Tighten intake manifold bolts to 40 foot-pounds. Perform cylinder compression test. Compression should be in the 120 - 150 pounds range and not vary more than 40 pounds. Use compression pressure only as a guide in diag-

nosing engine trouble. An engine in good condition may exhibit higher pressures. Clean or replace spark plugs as necessary and adjust gap to 0.035 inch. Tighten to 10 foot-pounds. Inspect distributor primary wire and vacuum advance operation. Ignition timing and carburetor adjustments should not be attempted by the coach owner because of emission control requirements which require sophisticated test equipment and certification. See paragraph 4-27 for clean air emission control servicing.

#### 4-29. COOLING SYSTEM (fig. 4-24)

Cooling system consists of a large capacity radiator with an integral transmission oil cooler to maintain the power plant temperature within an efficient range. The system has a water pump, thermostat, fan, and hoses and lines to circulate the coolant under all operating conditions. Check coolant level frequently. Always use a premixed coolant of 50% ethylene glycol and water to provide protection against freezing (to -34°) and corrosion.

#### **Warning**

Never add coolant to the radiator when the engine is overheated. Do not loosen or remove cap to cool an overheated engine.

Use caution in removing the pressurized (13 psi) radiator cap when the temperature is high. Place a cloth over the cap and loosen by turning counter-clockwise to the first stop until all pressure is released. Then push cap down and turn it further in the same direction for removal. Maintain coolant at a level approximately 3-1/2 inches below top of filler neck.

#### **Caution**

Monitor engine temperature gauge frequently. Temperature should NOT exceed 250°F.

**a. Fan Belt Tension (fig. 4-25).** Fan belt tension should be checked frequently and, if necessary, adjusted. Adjust belt to proper tension by loosening idler pulley pivot screw and slotted hole screw. Place a 1/2 inch socket drive wrench in square slot and adjust belts to 80 - 100 pounds on a new belt, 60 - 75 pounds on a broken-in belt. Torque pivot screw and slotted-hole screw to 100 foot-pounds.

**b. Hoses and Connections.** Check all hoses and coolant connections for leaks and corrosion due to blockage. Replace any doubtful hoses and tighten connections.

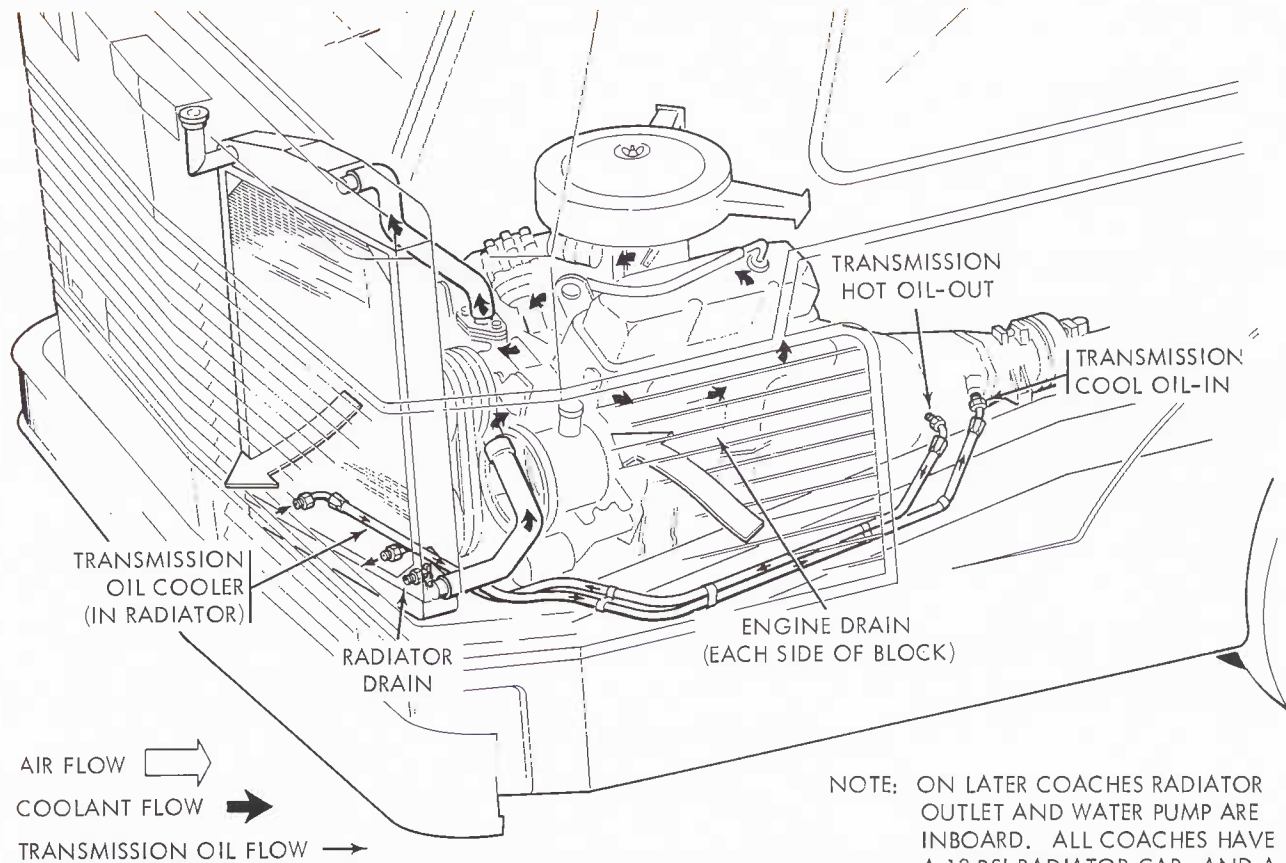

SD-35

Figure 4-24. Cooling System Flow

c. **Thermostat.** If necessary to replace thermostat, make certain heat range is correct for your coach. Factory-installed thermostat begins to open at 177 - 184°F. The use of a lower range thermostat is not recommended.

d. **Fill and Drain.** In the spring and fall, the cooling system should be completely drained, flushed, and refilled with a premixed coolant of 50 percent ethylene glycol and water. Discard old solution. To drain system, open drain cock at the bottom of radiator and at each side of engine block. Close all drain cocks and refill system. Check frequently during cold weather to avoid freeze-up. Occasionally check the radiator for any foreign matter that would impair air circulation.

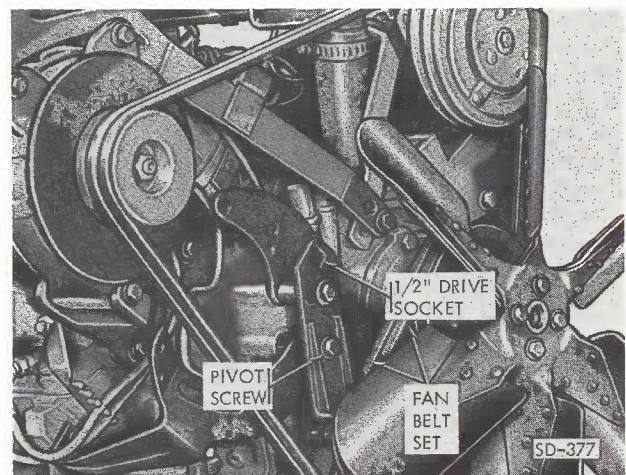

Figure 4-25. Fan Belt Adjustment

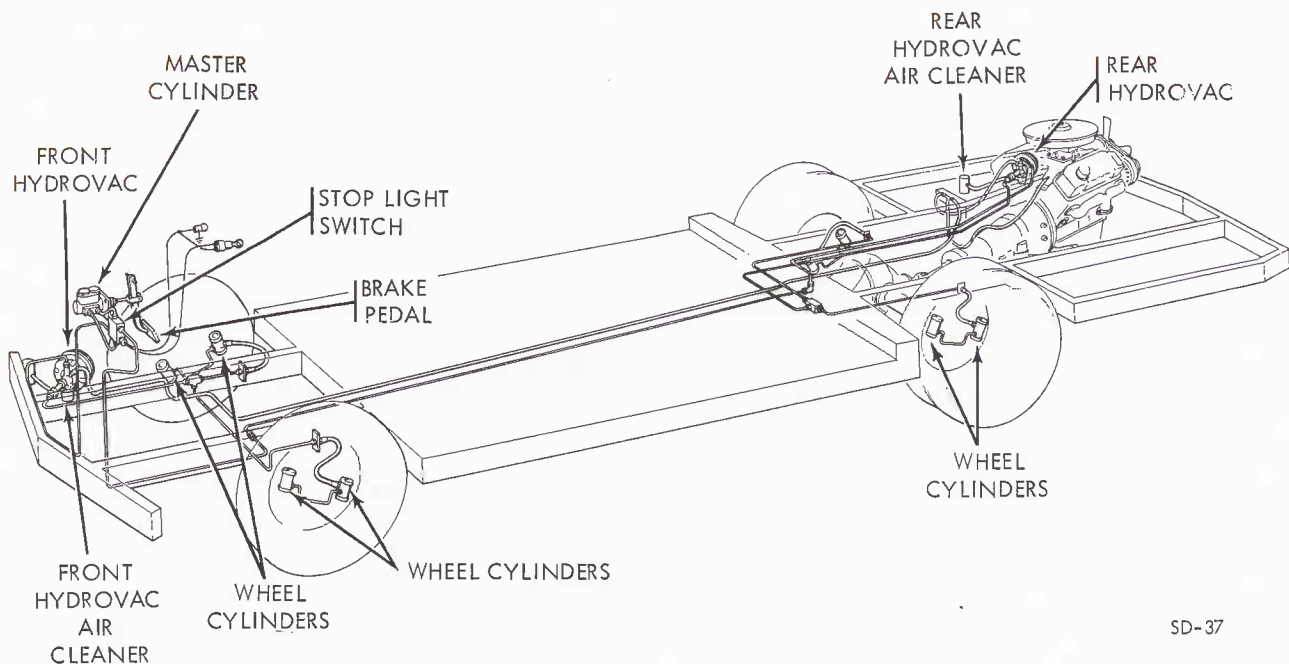

Figure 4-26. Brake System - Service

SD-37

#### 4-30. BRAKE SYSTEM-SERVICE AND PARKING

a. Service. When you depress the brake pedal on your coach, two assist units, technically dubbed "Hydrovac," operate to power the application of the brakes (fig. 4-26). A slight movement of the brake pedal opens an engine vacuum line which activates both the front and rear hydrovac units to increase the brake fluid pressure and apply the brakes. The front hydrovac boosts the pressure to the front wheel brakes, and the rear hydrovac boosts pressure to the rear brakes. Construction is such that, in case of an engine failure and loss of vacuum power, the brakes will function as in a conventional nonpowered hydraulic brake system. More physical effort is required, however, than when the hydrovac is operating.

b. Parking. The parking brake lever located next to the driver's seat is linked by cable with an internal expanding brake at the rear of the transmission. The parking brake shoes clamp the drum on the transmission to lock up the power train.

c. Bleeding Service Brake System. Brake bleeding should be performed only by a qualified service technician. However, detailed brake bleeding pro-

cedures are provided in the 2900R SERVICE MANUAL which is available, at a nominal cost, to the coach owner.

d. Brake Shoe Adjustment. The fluid displacement requirements of a hydraulic brake system depend on how well the brakes are adjusted. When properly adjusted, there is a minimum of brake shoe movement necessary to bring linings into contact with the drums. Each wheel brake is equipped with an upper and a lower wheel cylinder and each shoe floats at its midpoint. Therefore, the shoes move outward evenly against the drum for total and immediate effectiveness. There is but one point of adjustment at each shoe, namely the adjusting screw. Each adjusting screw is threaded into or out of its anchor support. It is sometimes called "star wheel" and used to establish desired lining to drum clearance. To increase or decrease brake clearance rotate star wheel.

For maximum safety adjust brakes when pedal drops to within 2 to 3 inches of floor board on a hard application.

Brake shoe adjustments should be performed only by a qualified service technician. However, detailed brake adjustment procedures are provided in the 2900R SERVICE MANUAL which is available, at a nominal cost, to the coach owner.

After continued operation, the parking brake cable may stretch or the drum lining will wear until the adjusting knob will no longer establish the proper brake drum pressure. At this point, the parking brake system will require a brake system service adjustment. This adjustment should only be performed by a qualified service technician. However, a step-by-step procedure is provided in the 2900R SERVICE MANUAL which is available, at a nominal cost, to the coach owner.

e. Parking Brake Adjustment (fig. 4-27). The parking brake lever cable tension may be adjusted for proper brake function by turning adjusting knob on brake lever clockwise to tighten; counter-clockwise to relieve tension.

## 4-31. EXTERIOR BODY MAINTENANCE

The exterior of your motor coach is a polyester gelcoat reinforced with chopped fiberglass moulded into a tough-wearing impervious material. Glass fibers, imbedded into a polyester resin base, are intricately laced into a hard, durable, and brilliant finish that resists weather, road salts, and the ultra-violet rays of the sun. The finish is capable of sustaining damage, but if damage should occur it is usually limited to the area of impact and would be economical to repair.

a. Care and Cleaning. To wash your coach, use a mild dishwashing detergent. Apply liberally from the top down and rinse with clear water. Stubborn stains can be removed by using paint thinner or acetone. Use a 220 grit wet-dry type sandpaper and wet with water to provide a mild abrasive action for removal of heavy road dirt and grime. Do not use scrapers, wire brushes, or other metal tools. Dulled areas may be restored by rubbing with an automotive-type body cleaning compound followed by a light application of liquid wax.

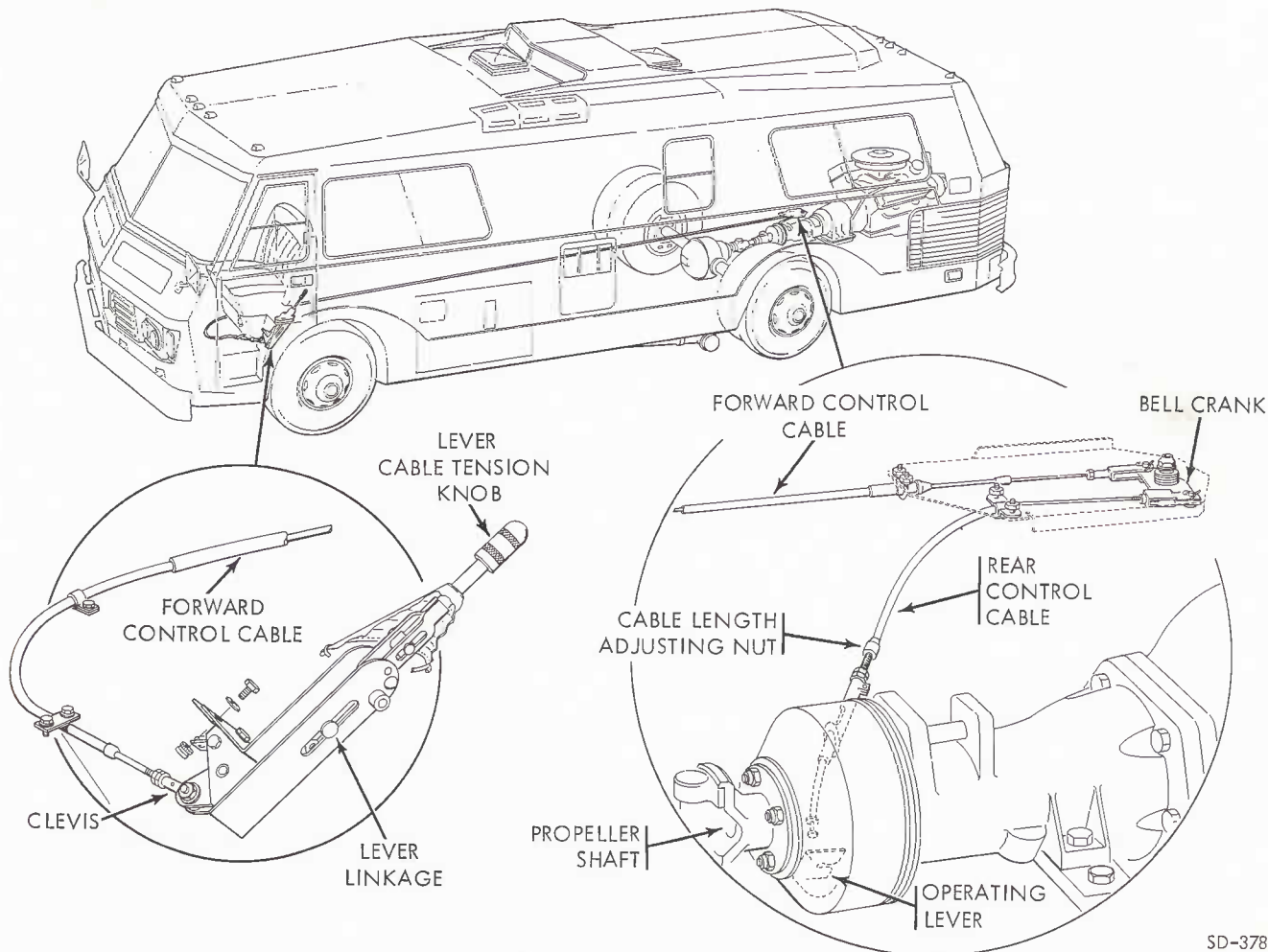

Figure 4-27. Parking Brake and Cable

SD-378

## Caution

Abrasive scouring-type cleaners will scratch surface.

b. Maintenance. A scratch or gouge that penetrates only slightly into the laminate is considered minor and repair can be accomplished by using hand tools with a power drill and sander. We recommend that repair be done by a qualified fiberglass repair center; however, if you do it yourself, you will need the following items:

Sandpaper and sanding discs (24 to 80 grit and 360 to 600 grit)  
Electric drill with sanding attachment and burr bit  
Files  
Sanding block  
Orbital or flat sander  
Xylol or equivalent solvent  
Heat gun or heat lamp  
Body filler and squeegee  
Glazing putty  
Goggles

A suggested method for repairing minor fiberglass damage is listed below:

(1) Check temperature and humidity and compare with recommendations on filler can label. Generally 70°F and 70 humidity are considered ideal; however, never work with the surface in direct sunlight.

(2) Clean the damaged area with xylol or equivalent; then inspect area closely.

(3) Push on the area immediately surrounding and underneath the damaged area to determine the extent of damage.

(4) Use a power drill and form a V-groove the length of the scratch or gouge.

## Caution

Always wear goggles when cutting, drilling, or sanding.

(5) Remove flaky edges and feather the pain surface back about 1/2 inch beyond the damage area by hand-sanding or power sanding with 360 grit sandpaper; then clean area with dry cloth.

## Caution

Do not wipe with solvent.

(6) Mark off the undamaged surface, leaving a working area of approximately 5 inches surrounding the repair area.

(7) Mix enough polyester body filler, per instructions on container, to reestablish the surface.

## Caution

Mix filler on formica, teflon, or other hard surface. Do not work on a porous surface such as cardboard.

(8) Apply and spread filler with a plastic squeegee, making sure to remove large air bubbles. Allow filler to extend above original surface to allow for shrinkage.

(9) Let filler set up until it is firm to the touch. Then re-establish original contour by filing off excess, still leaving the filler level slightly higher than original surface.

(10) Use a heat lamp to preshrink filler. A minimum temperature of 120°F is required for shrinkage.

## Caution

Keep heat source at least 12 inches away from repair area.

(11) Power sand the filler with 360 grit sandpaper until it is smooth and even with original surface.

(12) If filler is slightly porous (has fine pinholes), apply a thin coat of glazing putty.

(13) Finish by sanding with a sanding block and 600 grit wet sandpaper.

## NOTE

If filler is pockmarked, do not use glazing putty. Instead, apply another layer of body filler.

(14) Complete the repair by cleaning the area with air. Remask, if necessary; then spot prime and paint.

(15) Rub area with a fine rubbing compound and apply a coat of wax.